

# Ikelite

## External Color-Correction Filters

### Installation Instructions

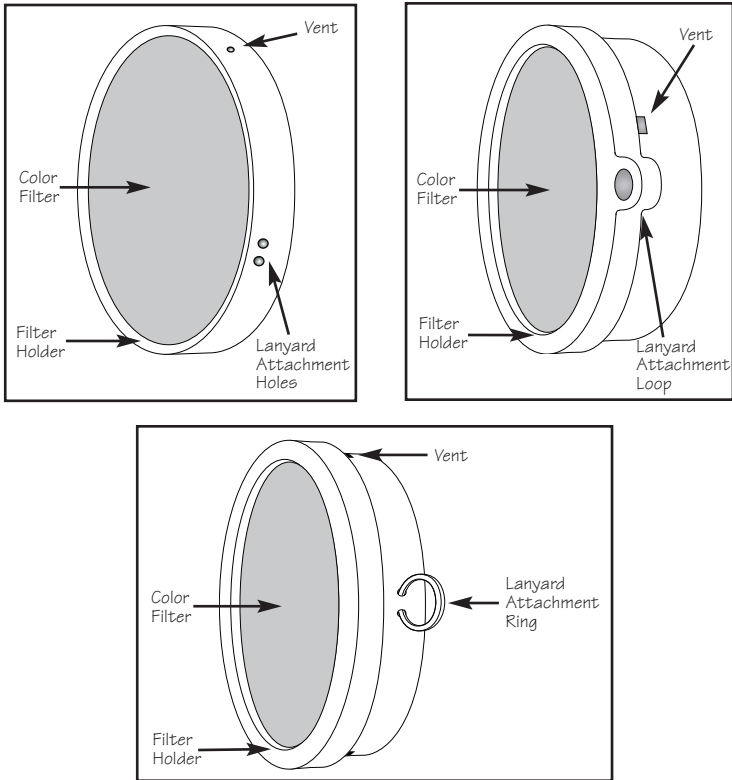

**Note:** Please read all instructions before using this product.

## EXTERNAL COLOR-CORRECTION FILTERS

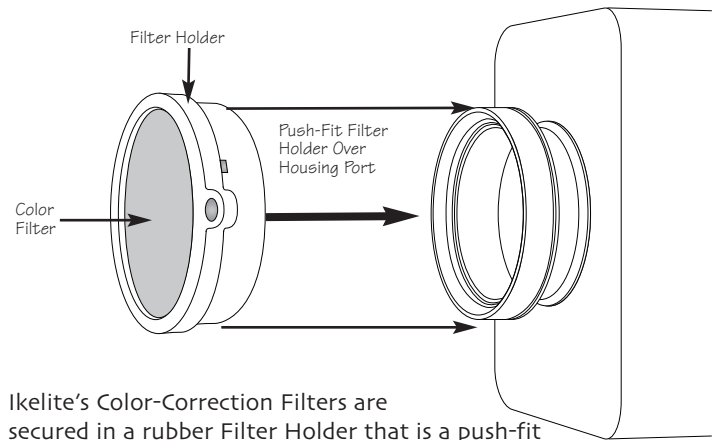

Ikelite's Color-Correction Filters are secured in a rubber Filter Holder that is a push-fit over the housing port on digital still or video housings. Filters can also be used on the Ikelite W-20 and WP-80 wide-angle accessory lenses. The red filter is for tropical (blue) water and the magenta filter is for cold (green) water. The filters enhance the color balance in natural light photography. Useful to depths of approx. 24m (80'), subject to sufficient available light. Filter use is not recommended above water or with flash.

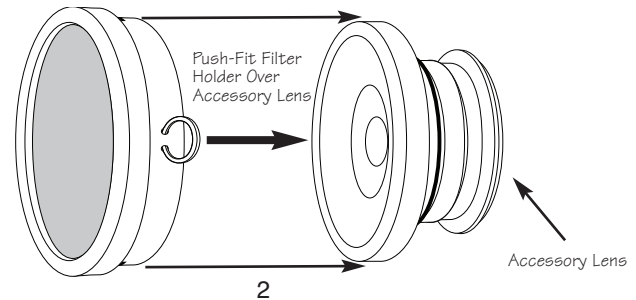

## INSTRUCTIONS

### Installation:

The External Color Filter secures over the front of the housing port or accessory lens. If not attached, attach the lanyard to the Filter Holder. Attach the small end of the Lanyard to the Lanyard Attachment on the Filter Holder. Slide the large end of the lanyard through the small end loop, and pull tight. Open large end of the lanyard and place over the housing handle so that the lanyard and color filter hang safely from the housing tray. When ready to use, push the filter over the housing port or accessory lens. This will be easier to do underwater and it is recommended that you always install the filter underwater.

### Cleaning:

The external filter is protected with a scratch resistant coating. Special care should always be taken when handling. Immediately after use, rinse and gently dry the filter to avoid water spotting. If necessary, use a mild non-abrasive soap solution or lens cleaner, and a very soft cloth to clean the filter. Minor scratches will usually fill with water and not affect the picture quality.

### Usage:

If you enter the water with the filter secured on the port or accessory lens, you will need to remove the filter underwater to gently remove any trapped air bubbles. You can then re-install the filter.

It is extremely important that no air bubbles are trapped between the port or accessory lens and filter. The camera may focus on any trapped bubbles resulting in an out-of-focus image.

### NOTE:

For best results do not shoot directly into sunlight.

## Ikelite Limited Warranty

All Ikelite products are warranted against any manufacturing defects for a period of one year from the date of purchase. Defective products should be returned prepaid to Ikelite. Ikelite will, at its discretion, repair or replace such products, and will return to customer prepaid. All other claims, of any nature, including, but not limited to, bulb failure are not covered. Except as mentioned above, no other warranty, expressed or implied, applies to this Ikelite product.

## Returning Products for Service

Ikelite is most interested in performing any service to assure that all products perform as intended. For repair or service, return the product to the address below with your name, address, phone number and a brief description of the problem. Evidence of purchase date must be provided to obtain warranty service.

### Ikelite Underwater Systems

Attn: Repair Department  
50 W 33rd Street  
Indianapolis, IN 46208 USA

317-923-4523  
email: [ikelite@ikelite.com](mailto:ikelite@ikelite.com)  
[www.ikelite.com](http://www.ikelite.com)

## EXTERNAL COLOR-CORRECTION FILTERS

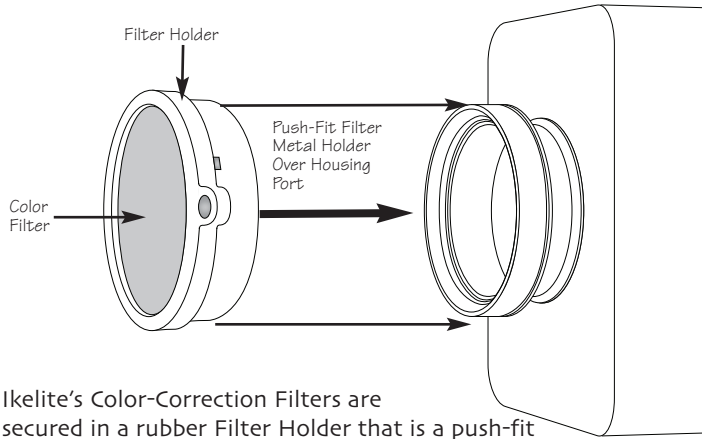

Ikelite's Color-Correction Filters are secured in a rubber Filter Holder that is a push-fit over the housing port on digital still or video housings. Filters can also be used on the Ikelite W-20 and WP-80 wide-angle lenses. The red filter is for tropical (blue) water and the magenta filter is for cold (green) water. The filters enhance the color balance in natural light photography. Useful to depths of approx. 24m (80'), subject to sufficient available light. Filter use is not recommended above water or with flash.

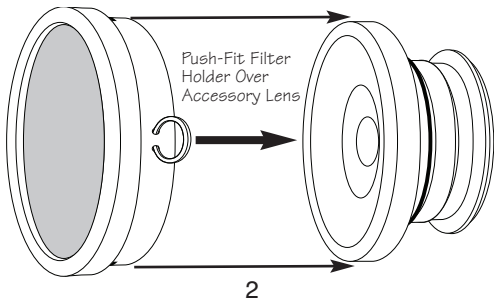

## EXTERNAL COLOR-CORRECTION FILTERS

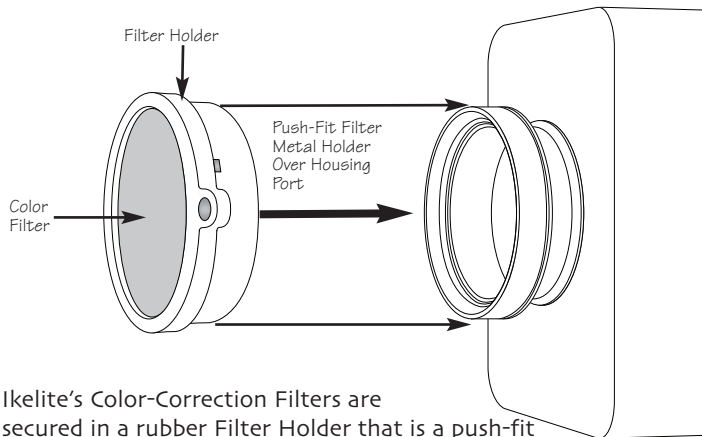

Ikelite's Color-Correction Filters are secured in a rubber Filter Holder that is a push-fit over the housing port on digital still or video housings. Filters can also be used on the Ikelite W-20 and WP-80 wide-angle lenses. The red filter is for tropical (blue) water and the magenta filter is for cold (green) water. The filters enhance the color balance in natural light photography. Useful to depths of approx. 24m (80'), subject to sufficient available light. Filter use is not recommended above water or with flash.

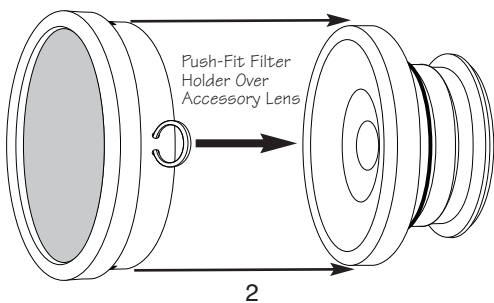

## INSTRUCTIONS

### Installation:

The External Color Filter secures over the front of the housing port or accessory lens. If not attached, attach the lanyard to the Filter Holder. Attach the small end of the Lanyard to the Lanyard Attachment on the Filter Holder. Slide the large end of the lanyard through the small end loop, and pull tight. Open large end of the lanyard and place over the housing handle so that the lanyard and color filter hang safely from the housing tray. When ready to use, push the filter over the housing port or accessory lens. This will be easier to do underwater and it is recommended that you always install the filter underwater.

### Cleaning:

The external filter is protected with a scratch resistant coating. Special care should always be taken when handling. Immediately after use, rinse and gently dry the filter to avoid water spotting. If necessary, use a mild non-abrasive soap solution or lens cleaner, and a very soft cloth to clean the filter. Minor scratches will usually fill with water and not affect the picture quality.

### Usage:

If you enter the water with the filter secured on the port or w/a lens, you will need to remove the filter underwater to gently remove any trapped air bubbles. You can then re-install the filter. It is extremely important that no air bubbles are trapped between the port or w/a lens and filter.

### Light Refraction:

Do not shoot into the sun while using the external color filter because it may create a noticeable refraction effect.

## INSTRUCTIONS

### Installation:

The External Color Filter secures over the front of the housing port or accessory lens. If not attached, attach the lanyard to the Filter Holder. Attach the small end of the Lanyard to the Lanyard Attachment on the Filter Holder. Slide the large end of the lanyard through the small end loop, and pull tight. Open large end of the lanyard and place over the housing handle so that the lanyard and color filter hang safely from the housing tray. When ready to use, push the filter over the housing port or accessory lens. This will be easier to do underwater and it is recommended that you always install the filter underwater.

### Cleaning:

The external filter is protected with a scratch resistant coating. Special care should always be taken when handling. Immediately after use, rinse and gently dry the filter to avoid water spotting. If necessary, use a mild non-abrasive soap solution or lens cleaner, and a very soft cloth to clean the filter. Minor scratches will usually fill with water and not affect the picture quality.

### Usage:

If you enter the water with the filter secured on the port or w/a lens, you will need to remove the filter underwater to gently remove any trapped air bubbles. You can then re-install the filter. It is extremely important that no air bubbles are trapped between the port or w/a lens and filter.

### Light Refraction:

Do not shoot into the sun while using the external color filter because it may create a noticeable refraction effect.