

# IKELITE VIDEO CASE

SUPPLEMENTAL INSTRUCTIONS FOR

#6014.11 JVC GZ-MG730, 530, 532

#6014.12 JVC GZ-MG 730 Package

This supplemental set of instructions describes additional features specific to your housing model. Prior to testing the system in the water, please read this supplement along with the general instruction manual to become familiar with its features and functions.

Ikelite Video Cases are slightly negative in salt water for stability. This housing has been water pressure tested at the factory and has a working depth of 60m (200').

## HOUSING CONTROLS

- Power On/Off
- Start/Stop
- Snap Shot
- Zoom
- Mode Switch
- Program AE Dial
- Lens Switch

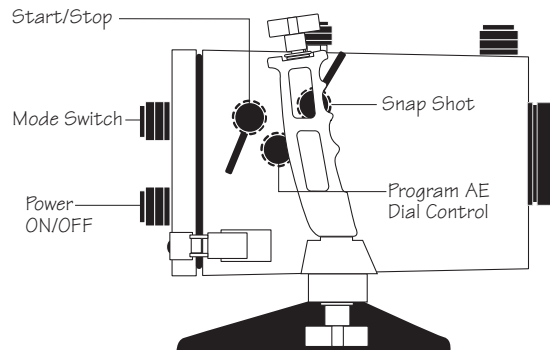
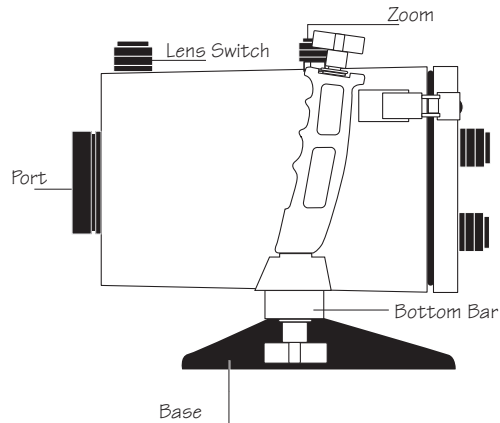

## MAIN O-RING #0109

O-rings last several years if properly maintained. Control seals should not need to be replaced as long as the control shafts are kept clean and lightly lubricated.

## PREPARATION

### PACKAGED WITH HOUSING

- External UR/Pro Color Filter
- Silicone Lubricant
- Lens Shade

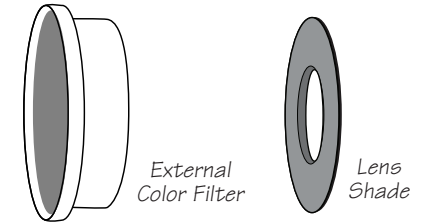

### COLOR FILTER

The installation and usage of the external UR/Pro color filter is described in the general instruction manual.

### OPTIONAL WIDE ANGLE LENS

The housing's port accepts optional 67mm threaded waterproof Wide-Angle lenses such as the Ikelite #6420 W-20, Epoque DCL-20 and Inon UWL-100 Type 2. These waterproof lenses secure to the outside of the lens port.

Should you elect to use an optional waterproof lens, carefully thread the lens on the front of the lens port on the housing. The lens threads are very fine; DO NOT cross thread. It should screw on very easily. If it is difficult to turn, you are cross threading.

### INTERNAL WIDE-ANGLE LENS OPTION

Special ports are available for use with the Raynox HD-5050 Pro high definition wide-angle lens. optional ports sold separately as dome port #9304 or flat lens port #9304.1. Raynox HD-5050 Pro lens not included. Lens **not** available for purchase through Ikelite.

### LCD MONITOR / EXTERNAL MIRROR

The camera's LCD monitor can be viewed thru the rear of the housing. Open the LCD monitor on the camera. Once the camera is secured to the camera tray, press the LCD screen against the shade secured to the back of the housing.

### BATTERY AND TAPE

Install a fully charged JVC battery on the camera:

- JVC VF-808U      JVC VF-823U
- JVC VF-815U

Other brand batteries may not fit inside the housing. If the battery selected overhangs the camera tray, then the battery is too large and will cause the housing to leak.

Make sure you have loaded an appropriate digital cassette tape in the camera.

### FINAL PREPARATION

Remove the lens cap, lens hood and cord from the camera. Otherwise, they may interfere with the housing seal.

The camera's auto focus feature is utilized underwater. For best results, move in close to your subject and use the wide angle range to shoot thru as little water as possible. The full zoom range is accessible underwater.

Chart shows recommended initial settings underwater.

CAMERA	SETTING
Power On/Off	- Camera (On)
Zoom Lever	- Wide Angle Setting
Focus	- Auto Mode

# INSTALLATION

## CAMERA TRAY

The camera mounts to the tray, which extends from the back plate of the housing.

**DO NOT** remove the tray from the back plate. The camera strap **MUST** be positioned underneath the camera tray as noted below.

1. Remove camera strap from front loop on the camera.
2. Open the camera LCD screen.
3. Place the camera against the stabilizing pins on the tray. Secure camera with the tripod mounting bolt. The camera should fit easily on the tray and should be parallel with the sides of the tray.
4. Loop the camera strap underneath the camera tray and attach the open end of the strap around the spring pin on the housing back.
5. Press the LCD screen against the shade on the back.

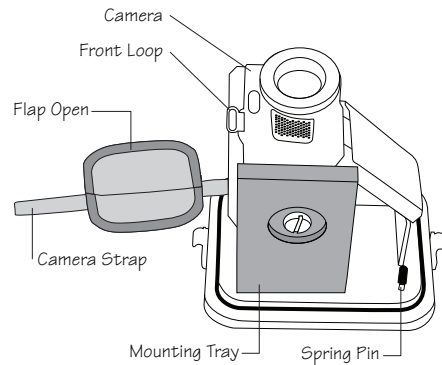

Remove the camera strap from the front loop on the camera.

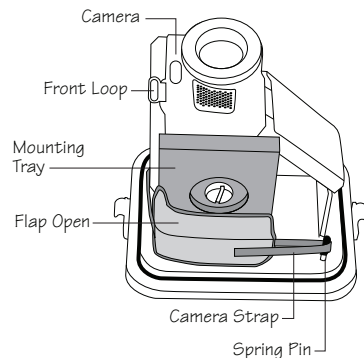

Loop the camera strap underneath the camera tray and attach the open end of the strap around the spring pin on the housing back with the flap open.

# INSTALLATION continued

## INSERTING THE CAMERA

Check that the clean o-ring is properly positioned on the lip of the clear back plate. Place the lid snaps in the open position.

Once the camera is mounted to the tray and the camera strap is secured underneath the tray, pull the housing controls out to provide clearance for the camera. Align the back plate with the clear housing and slowly place the back plate against the housing.

**DO NOT** force this installation; if the controls are out of the way and everything is lined up properly, the camera and tray will fit easily inside. Make certain that the tray is completely in the housing. The front should be flat against the housing and **NOT** tilted on one side.

## HOUSING CONTROLS

Slide the housing controls back in place making sure they properly align with the camera functions. Fasten the opposite lid snaps at the same time--**DO NOT** fasten one at a time.

Operate each control to see how it works with the camera. Some controls such as start/stop will be used frequently. Other controls may seldom be utilized. Refer to your camera owner's manual for the proper function of each camera control. Look thru the back to be sure that you can see into the viewfinder.

When using the housing controls, especially the start/stop, **DO NOT** use excessive force because you could damage the camera.

## CAUTION

*Remove the lens cap and cord from the camera. Otherwise, the cord may interfere with the housing seal.*

*If the housing controls are not properly positioned, they could interfere with the housing seal.*

## IKELITE UNDERWATER SYSTEMS

50 West 33rd Street • PO Box 88100 • Indianapolis, IN 46208 USA • 317.923.4523

Email: [ikelite@ikelite.com](mailto:ikelite@ikelite.com) • [www.ikelite.com](http://www.ikelite.com)