



# IKELITE DS125 Substrobe

Thank you for purchasing an Ikelite SUBSTROBE. Ikelite brings 40 years of underwater photographic and lighting experience to the strobe market. Ikelite Substrobes are designed and built in the USA by Ikelite to suit both the professional and the amateur photographer.

## DS125 SUBSTROBE

The Ikelite DS125 strobe combines high intensity output and wide coverage angle in a compact, versatile design. This strobe features 110 watt-sec. intensity and covers a full 100° using the diffuser. Special soft-lite reflector provides rich reds, oranges, and warmer flesh tones.

The Ikelite DS125 strobe is preflash compatible and operates with both traditional film cameras and digital still cameras. Multiple firing modes are featured, including TTL/Auto exposure. Add the optional Ikelite DS Sensor #4100.5 for wireless TTL/Auto slave capability with select cameras or the Ikelite EV-Controller #4100.6 for 10-manual power settings.

The DS125 electronics are safely sealed separately from the battery pack. The industrial grade NiMH batteries recycle in an incredible 1.0 seconds and the NiMH pack is easily interchangeable with a spare unit. When in the "TEST" position the fuel gauge references the remaining battery capacity. Aim the DS125 and illuminate your subject's colors with the built-in modeling light / night diving light.

## OVERVIEW OF DS125 FEATURES

- Separate power and firing mode switches.
- Interchangeable battery pack features industrial grade NiMH batteries.
- LED fuel gauge approximates the remaining battery capacity.
- Visual ready light indicates when strobe has recycled.
- Female Ikelite bulkhead connector accepts different camera sync cords, the Ikelite DS Sensor #4100.5 or EV-Controller #4100.6.
- Exposure guide label references recommended exposure settings.
- Separate diffuser provides softer lighting and wider coverage angle.
- Strobe mount accommodates most Ikelite arm systems.

## BECOMING FAMILIAR

Before using the Ikelite Substrobe, please read this owners manual thoroughly and retain for future reference. We recommend that you become familiar with the features and functions of the Ikelite Substrobe before trying the camera and strobe in the water. And if you have not done so, we suggest reading your camera owner's manual.

# SWITCHES / FUEL GAUGE

The DS125 features separate switches for power on/off and firing modes. The arrow on the switch points to the selected position.

## ON/OFF SWITCH

**OFF:** The horizontal switch position is OFF. The adjacent tab locks the switch in the OFF position. To unlock, slide the tab away from the switch. Always turn the Substrobe OFF before opening the strobe.

**ON:** There are two ON positions. Rotating the switch clockwise to the first ON position turns on the power to the Substrobe. Further rotation of the switch clockwise to the second ON position turns on both the power to the Substrobe and the modeling light.

**TEST:** Occasionally check the battery capacity by rotating the switch counter-clockwise to the TEST battery position and referencing the fuel gauge on the side of the strobe. The TEST battery position also turns ON the modeling light as a reminder that the switch is in the TEST position.

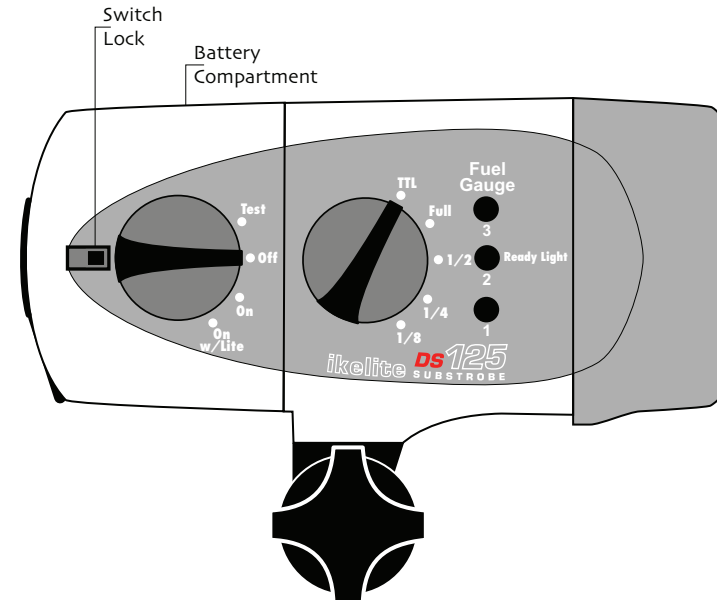

## FUEL GAUGE

When the switch is rotated to the TEST position, the fuel gauge on the side of the strobe will display 0, 1, 2, or 3 red LED lights indicating the remaining charge in the battery pack (see below). A fully charged NiMH pack will provide at least 250 full power flashes and all 3 LED's should light. When no LED's are illuminated, then the battery capacity is low and you may have less than 36 full power flashes remaining. For general guidelines, refer to the following list:

- 3 LED's - above 75%
- 2 LED's - above 50%
- 1 LED - above 25%
- No LED - less than 25%

## CONFIDENCE SIGNAL

The DS125 strobe features a confidence signal indicator light that will glow if the strobe properly exposes the picture. The #3 LED on the fuel gauge will glow GREEN for three seconds if the DS125 strobe quenches, indicating that the strobe has provided proper exposure. This green confidence light illuminates only in the TTL exposure mode.

## FIRING MODE SWITCH

Multiple firing modes are featured: TTL/Auto and four manual power settings: Full, 1/2, 1/4, and 1/8.

**TTL/Auto - Thru-The-Lens/Auto Exposure:** The camera automatically signals the strobe to turn off when the exposure is correct. The camera must feature compatible TTL/Auto exposure to utilize this mode on the DS125 when connected directly to the camera. (See "Compatible Cameras" and "TTL/Auto Exposure" sections). The TTL/Auto firing mode **MUST** be selected when connecting the optional DS Sensor #4100.5 or EV-Controller #4100.6.

**Full - Full Power Manual Exposure:** The strobe fires at full power each time. You must select the correct exposure manually. Set the camera aperture based on the subject distance (see "Exposure Guide" section).

**1/2, 1/4, 1/8 - Manual Exposure Modes:** Select the appropriate power setting to manually balance the strobe output for available light. Select 1/2, 1/4, or 1/8 power when the strobe-to-subject distance is fixed and the manual full power setting would over-expose with the camera aperture you have selected. The difference between **each power setting** is one full f-stop; moving from Full power to 1/2 power decreases the light output by one full f-stop. Changing the power setting does not alter the coverage angle.

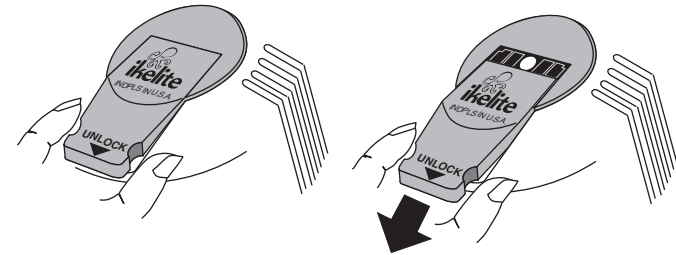
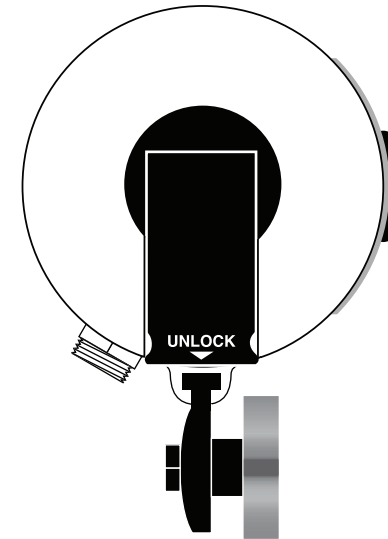

Pull Out

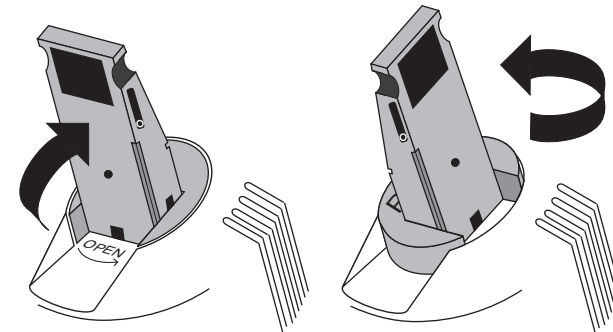

Flip Up

Rotate

# OPENING AND CLOSING

Always turn the Substrobe OFF before opening the strobe.

## OPENING THE STROBE

Turn the strobe OFF, and place the strobe face down on a flat surface.

Slide the locking lever out by either grasping the sides of the lever and pulling it out OR use your thumb to apply slight pressure to the top of the lever and slide it out.

Flip the lever up and then rotate the lever counter-clockwise 90°. The internal spring automatically pushes open the strobe. Lift the rear section off of the strobe front. The rear section is the NiMH battery pack for the strobe.

The rear NiMH pack does NOT remain waterproof when removed from the strobe. Therefore, we suggest keeping the open portion of the NiMH pack pointed down while removing to eliminate the possibility of water droplets falling inside. The NiMH batteries remain permanently secured inside the pack.

The front section of the DS125, which houses the main electronics, is safely sealed separately from the NiMH pack. The front section will remain waterproof when the NiMH pack is removed. However, avoid salt-water contact with the battery pins. Damage/corrosion can cause short circuiting. **DO NOT** disassemble the strobe or the NiMH pack. We suggest storage of your strobe with the locking lever OPEN to allow any hydrogen/air mixture to escape.

## O-RING

The o-ring is located on the inside rim of the NiMH pack. Keep the o-ring and the sealing surfaces clean. **DO NOT** stretch the o-ring when cleaning. It is not necessary to lubricate the o-ring. Never use spray lubricant because it may crack the plastic.

## RECHARGE THE BATTERIES

See "NiMH Pack" section for recharging information.

## CLOSING THE STROBE

Make sure the power switch has been rotated to the off position.

Place the front of the strobe face down on a flat surface. Check that the o-ring and sealing surfaces are clean; make sure the o-ring is positioned properly inside the rim of the NiMH pack. Place the locking lever in the open position (slide the lever out, flip the lever up, and rotate the lever counterclockwise).

Align the front and rear sections of the strobe. Lower the NiMH pack onto the front section of the strobe. Proper alignment of the two sections is extremely important to avoid possible damage to the internal components.

To seal the strobe, simply press down slightly on the rear of the NiMH pack and rotate the lever clockwise. Flip the lever down and then slide the lever in to the locked position to properly seal the strobe.

# MODELING LIGHT

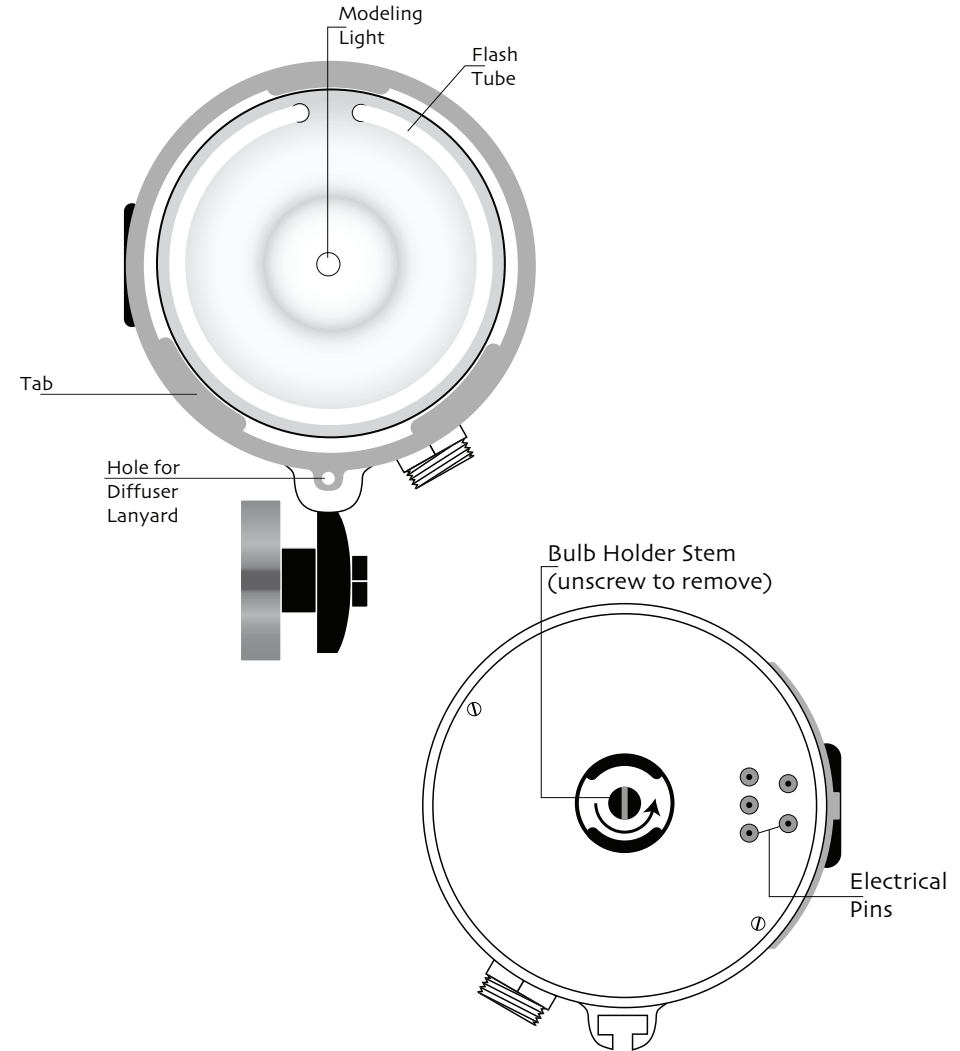

## MODELING LIGHT

The modeling light is located in the center of the strobe front; it is ideal as an aiming light and night diving light. The second ON position turns on both the power to the Substrobe and the modeling light. Note that the TEST battery position also turns ON the modeling light as a reminder that the switch is in the TEST position.

It is normal for the modeling light to flicker every few seconds as the strobe capacitors recharge. The momentary power drain on the batteries causes the flickering as the strobe recycles.

### BULB

The bright 7.2V krypton modeling light bulb #0042.34 draws the equivalent of under 50 full power flashes per hour.

### CHANGING THE BULB

The modeling light bulb is accessed from inside the front section of the strobe. Turn the strobe off and remove the NiMH pack. Then unscrew the long stem securing the bulb holder to the rear of the front section, and lift out the bulb holder. Tip the front of the strobe up and the modeling light bulb will drop out of the strobe.

The o-ring on the bulb holder provides a waterproof seal for the front section. Keep the o-ring clean. Use only enough lubricant to lightly cover the exposed portion of the o-ring; wipe off any excess with a clean cloth.

To install the new modeling light bulb, tip the front of the strobe down and carefully drop the bulb down into the center opening at the rear of the front section. The bulb will drop into the reflector opening in the strobe. Then replace the bulb holder in the front section and tighten to secure.

### AIMING THE STROBE

Use the modeling light to aim the strobe. Look thru the camera's viewfinder, and aim the strobe so that the modeling light shines in the center of your picture area. If your subject distance greatly changes, you should recheck the positioning of the strobe.

When using auto-focus cameras, the modeling light may be required in low light levels to illuminate your subject to allow the camera to auto focus.

## NiMH BATTERY PACK #4066.5

Rechargeable NiMH battery pack #4066.5 is compatible only with Ikelite's DS125 strobe. It is the only battery pack usable in the DS125. The rear section of the strobe is the NiMH battery pack for the strobe. Additional NiMH packs (rear sections) #4066.5 are available.

A fully charged NiMH pack provides at least **250 full power flashes**. It consists of six sub-C-cell industrial grade NiMH batteries (1.8Ah rating).

The NiMH pack does NOT remain waterproof when removed from the strobe. Therefore, we suggest keeping the open portion of the NiMH pack pointed down while removing to eliminate the possibility of water droplets falling inside. The NiMH batteries remain permanently secured inside the pack. **DO NOT disassemble the NiMH pack or charger.**

### CHARGING THE NiMH PACK

Recharge the NiMH pack after each use. **DO NOT** fully discharge NiMHs as this shortens the battery life. Definitely recharge the NiMHs if the modeling light dims or if the recycle time exceeds 8-10 seconds; batteries are nearly depleted. Store the NiMH pack fully charged and recharge the pack for a few hours each month. In our application, the NiMHs should NOT develop a memory. Fully discharging the NiMHs or allowing the NiMHs to completely lose a charge does far more damage than any risk of NiMH memory.

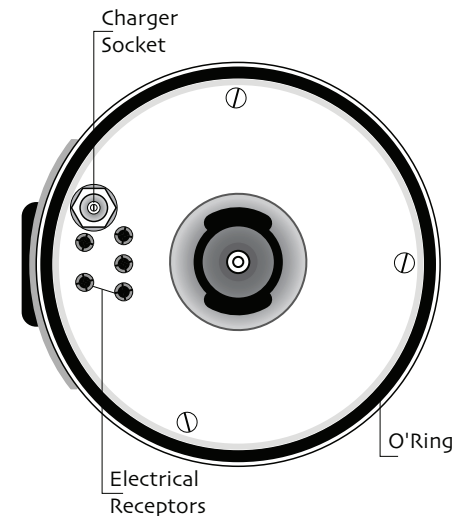

## SMART CHARGER #4066.1

### CAUTION

*Only use 5-6 cell Ikelite NiMH Charger*

#### SMART CHARGER #4066.1

The Smart Charger #4066.1 is a variable input voltage charger that automatically adjusts for the voltage of the power source, ranging from 100V to 240V. The Smart Charger adapts to current fluctuations in travel destinations with poorly regulated power. It provides more complete recharging, prolongs battery life, and offers trickle maintenance charge.

#### Charging Time

The Smart Charger will fully recharge the DS125 battery pack in 2 hrs.

#### Smart Charger Components

The Smart Charger #4066.1 offers use worldwide by accepting interchangeable adapter plugs for different electric wall outlets. It is packaged with four interchangeable charger plugs for USA, European, United Kingdom, and Australian electric outlets. Choose the appropriate charger plug for your location and slide the chosen plug on the back of the charger; it snaps into position. To interchange the charger plugs, press UP on the charger plug to unsnap it from the back of the charger and slide another plug into position.

#### Smart Charger Indicator Light

The charge indicator light on the Smart Charger shows the present recharge mode. It illuminates once connected to both the electric outlet and the Ikelite battery module. Recharge time with the Smart Charger is 2-hours for a full recharge of the DS125; afterwards the Smart Charger will automatically switch to provide a trickle maintenance charge. Only the Smart Charger is capable of providing a trickle maintenance charge permitting the NiMH pack to be continuously charged for extended periods.

#### CONTINUOUS illuminated light

Indicates that the NiMH module is being quick-charged.

#### SLOW BLINKING illuminated light

Indicates that the NiMH module is fully recharged and the charger is now providing a trickle maintenance charge, which permits the NiMH module to be continuously charged for extended time periods.

#### RAPID BLINKING illuminated light

Indicates that the NiMH module was virtually drained (discharged) and the module is being slow-charged to bring up the NiMHs. Once the NiMHs reach an acceptable level, then the charger will automatically switch to the quick-charge mode.

## STROBE READY LIGHT

#### READY LIGHT

The DS125 strobe features a visual ready light on the side of the strobe that glows when the strobe has recycled and is ready to fire. The middle #2 LED on the fuel gauge functions as the visual ready light.

#### CONFIDENCE LIGHT

The DS125 strobe also features a confidence light that will glow if the strobe properly exposes the picture. The #3 LED on the fuel gauge will glow GREEN for three seconds if the DS125 strobe quenches, indicating that the strobe has provided proper exposure. This green confidence light illuminates only in the TTL exposure mode.

## COMPATIBLE CAMERAS

The Ikelite DS125 strobe is preflash compatible and provides optimum performance with traditional film cameras, digital still cameras, and dSLR cameras in related Ikelite housings. The appropriate sync cord or sensor must be connected to trigger the strobe.

### TRADITIONAL FILM CAMERAS

The TTL/Auto exposure mode on the Ikelite DS125 strobe is compatible with the following TTL film camera systems. The camera reads the light passing thru-the-lens and automatically signals the strobe to turn off when the exposure is correct.

- SLR 35mm camera in the Ikelite SLR-AF Housing or another brand SLR housing that features Nikon-based TTL electronics.
- Nikonos V camera
- Nikonos RS camera

### DIGITAL STILL AND dSLR CAMERAS

#### Triggered via Sync Cord

Many Ikelite Digital Still Housings and Ikelite dSLR Housings feature TTL compatible circuitry connected with the Ikelite female bulkhead connector. Connect the Ikelite sync cord from the Ikelite housing to the DS125 strobe for TTL auto exposure.

Some other Ikelite housing models may feature the Ikelite bulkhead connector but offer only manual exposure because TTL conversion circuitry for that specific camera model may be unavailable or not yet developed.

#### Triggered via Slave Sensor

Some digital still cameras feature a small built-in flash **without** a means to connect a sync cord for an external strobe. Most of these cameras fire their built-in flash more than once while taking a flash picture. This happens so fast it is difficult to see, but the preflash helps the camera determine focus, exposure and color balance. After the preflash, the camera's built-in flash then fires to illuminate the subject and the picture is taken. For the external strobe to provide proper exposure, it **MUST** be preflash compatible to duplicate the preflash sequence. The Ikelite DS125 strobe is a **preflash compatible** strobe.

For those cameras that do not offer a means to connect a sync cord, the optional Ikelite DS Sensor #4100.5 may be compatible to trigger the DS125 strobe. Built-in slave sensors in the DS Sensor detect the light output from the camera's built-in flash and automatically signal the DS125 strobe to mimic the output by starting and stopping automatically. However, some of the newest digital still cameras feature a preflash sequence too quick for the Ikelite DS Sensor to identify proper auto exposure, and the Ikelite EV-Controller #4100.6 would then be recommended instead.

For maximum control using manual exposure, choose the optional Ikelite EV-Controller #4100.6, which connects to the DS125 strobe and provides 10-manual power settings in half-stop increments. The EV-Controller can be triggered using the built-in slave sensor or by connecting an optional sync cord.

## TTL / AUTO EXPOSURE

Most newer cameras and strobes feature TTL/Auto exposure, which automatically compensates for aperture, distance, extension tubes, and filters. Considering the wide range of apertures and subject distances, select the TTL/Auto exposure mode to easily control balanced lighting and close-up photography.

When the strobe fires, the camera reads the light and automatically signals the strobe to turn off when the exposure is correct. Both the strobe and camera must feature TTL/Auto exposure compatible electronics. The appropriate TTL sync cord or optional Ikelite DS Sensor is required to relay the TTL/Auto exposure signal from the camera to the strobe.

Please review the "Compatible Camera" section on the previous page for additional information.

### TTL SYNC CORDS

Ikelite offers interchangeable sync cords so that different camera systems can be connected to the DS125 strobe. A TTL sync cord is required to send the TTL/Auto exposure signal from the camera to the strobe.

### DS SENSOR #4100.5

The Ikelite DS Sensor provides auto exposure functions through slave sensors enabling the Ikelite Substrobe to be moved freely and positioned virtually anywhere. The DS Sensor connects only to Ikelite DS Substrobes and detects when the light from the TTL strobe connected to the camera starts and stops, and automatically signals the Ikelite Substrobe to start and stop in sync.

Many digital still cameras feature a small built-in flash without a means to connect a sync cord for an external strobe. For these situations, the optional Ikelite DS Sensor #4100.5 may be compatible to trigger the DS125 strobe. The sensor detects the light output from the camera's built-in flash and automatically signals the DS125 strobe to mimic the output. Some of the newest digital still cameras feature a preflash sequence too quick for the Ikelite DS Sensor to identify proper auto exposure, and the Ikelite EV-Controller #4100.6 would then be recommended instead.

## RAPID USE

The DS125 strobe should NOT be continuously fired more than 15 times in rapid succession. In such instances, allow the DS125 strobe to cool off for at least 10 minutes.

## CAMERA READY LIGHT

### Triggered via Sync Cord

When using a TTL/Auto exposure camera (film or digital) in an Ikelite TTL-compatible housing connected to the DS125 strobe by sync cord, the flash ready light in the camera viewfinder and the DS125 ready light will both glow when the Substrobe has recycled and is ready to fire.

If the Ikelite housing does not feature TTL compatible circuitry, then the ready light in the camera viewfinder would not be triggered when the strobe has recycled.

### Triggered via Slave Sensor

When using the DS125 strobe with the optional DS Sensor or EV-Controller (without optional sync cord), the strobe is not electronically connected to the camera. Therefore, the ready light in the viewfinder of the camera indicates when the on-camera flash has recycled. Reference both the camera and DS125 ready lights to make sure both flashes have fully recycled before taking the next picture.

## STROBE CONNECTION

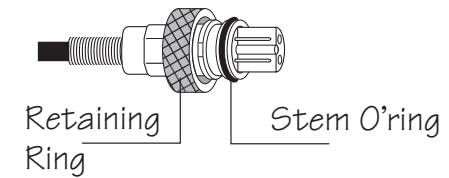
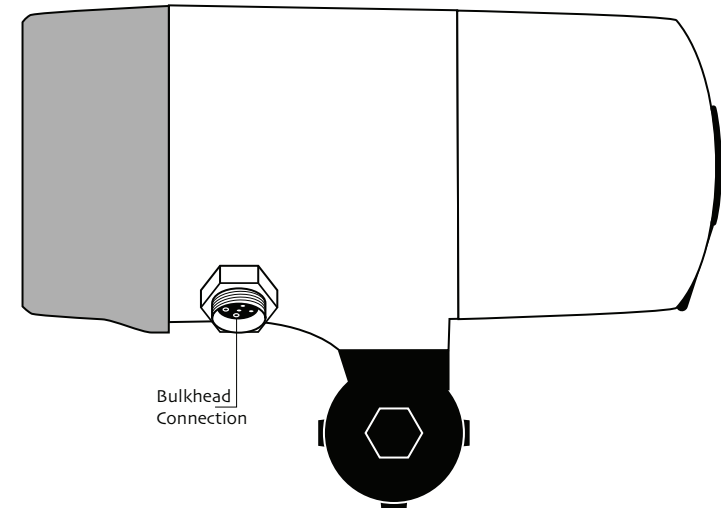

# STROBE CONNECTION

The female Ikelite bulkhead connector on the strobe permits different Ikelite sync cords or the Ikelite DS Sensor or EV-Controller to be connected. The sync cord or sensor relays the trigger signal to the Substrobe.

The removable waterproof cap seals the bulkhead connector when neither the cord nor the sensor is connected. The strobe bulkhead connector must be sealed to remain waterproof.

- **DO NOT** use TTL cord with a non-TTL Substrobe; you will damage the camera.
- **DO NOT** leave the sync cord or sensor connected to the strobe for *prolonged periods as electrolysis can make removal impossible.*
- **DO NOT** disconnect the sync cord or sensor from the strobe while underwater or when wet. *Connections are NOT waterproof when not connected.*

## CONNECTION TO STROBE

Connect either the sync cord or sensor to the Substrobe in the same manner.

***The connector threads are very fine; DO NOT cross thread.  
If it is difficult to turn, you are cross threading.***

1. Turn the Substrobe OFF and make sure all components are dry. Clean and lightly lubricate the stem o-ring and the strobe bulkhead connector threads. Check o-ring for nicks or cuts. Never use spray lubricant.

2. Note the positioning of the receptacles and pins. Properly align the end of the cord and insert into the strobe bulkhead connector. When using the #4103.51 cord, which connects an Ikelite housing to an Ikelite Substrobe, both cord ends are identical; either end can be connected to the strobe.

3. Hand-tighten the knurled retaining ring on the cord. Push the connector body further into the bulkhead connector and continue to tighten the knurled ring.

### LUBRICANT

- Use only Ikelite brand silicone lubricant with Ikelite brand o-rings as other *brand lubricants can cause the Ikelite o-rings to swell in size.*
- **DO NOT** use spray lubricant as it may cause cracking of the plastic.
- Ikelite silicone lubricant is provided for the cord o-ring. Use only enough *lubricant to lightly cover the o-ring; wipe off any excess with a clean cloth.*
- *Lubricant only reduces friction; it is NOT a sealant.*

# SYNC CORDS

- **DO NOT** use TTL cord with a non-TTL Substrobe; you will damage the camera.
- **DO NOT** leave the sync cord connected to the camera or strobe for prolonged periods as electrolysis can make removal impossible.
- **DO NOT** disconnect the sync cord from the camera or strobe underwater or when wet. *Connections are NOT waterproof when not connected.*

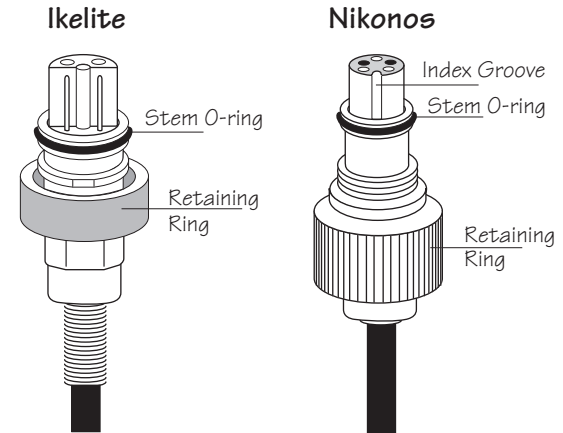

***The connector threads are very fine; DO NOT cross thread.  
If it is difficult to turn, you are cross threading.***

### LUBRICANT

- Use only Ikelite brand silicone lubricant with Ikelite brand o-rings as other *brand lubricants can cause the Ikelite o-rings to swell in size.*
- **DO NOT** use spray lubricant as it may cause cracking of the plastic. Ikelite silicone lubricant is provided for the sync cord o-ring. Use only enough *lubricant to lightly cover the o-ring; wipe off any excess with a clean cloth.*
- *Lubricant only reduces friction; it is NOT a sealant.*

# CAMERA CONNECTION

## IKELITE TTL CORDS

**#4103.51** Single strobe cord    **#4103.52** Dual strobe cord

These cords connect Ikelite Substrobes to Ikelite camera housings. Use TTL/Auto or manual exposure modes.

### Connect Ikelite Housing

1. Make sure all components are dry. Clean and lightly lubricate the stem o-ring and the housing connector threads. Check the o-ring for nicks or cuts.
2. Note the positioning of the receptacles and pins. Properly align the end of the sync cord and insert into the housing connector. When using the #4103.51 cord, both cord ends are identical; either end can be connected to the housing.
3. Hand-tighten the knurled retaining ring on the cord. Then push the connector body further into the housing connector and continue to tighten the knurled ring.

## NIKONOS TTL CORDS FOR FILM CAMERAS

**#4104.6** Single strobe cord    **#4104.62** Dual strobe cord

These cords connect Ikelite Substrobes to Nikonos IV, V and RS cameras, and non-Ikelite housings for traditional film cameras (see next section if using a non-Ikelite housing for a digital camera). Use either TTL/Auto or manual exposure modes with the Nikonos V / RS or suitable TTL/Auto exposure camera housing. When using the Nikonos IV or a non-TTL housing, set the strobe in the manual mode.

### Connect Nikonos Camera

1. Mount the camera tray underneath the Nikonos camera. Make sure all components are dry. Clean and lightly lubricate the stem shaft, o-ring, and retaining ring threads. Check the stem o-ring for nicks or cuts.
2. Align the index groove with the white dot of the camera flash socket, and insert the stem into the camera socket.
3. Rotate the retaining ring counterclockwise until it mates with the camera socket threads. Then carefully rotate the retaining ring clockwise and thread it into the camera body until snug.

### Check Connection for Nikonos V & RS

Turn ON the strobe and place camera in the TTL mode. Advance the camera to frame #1 and the ISO dial to 800 or above. The camera's ready light will blink if the connection is good. Afterwards, reset ISO dial for the correct film speed.

## NIKONOS CORDS FOR DIGITAL CAMERAS

**#4104.31** Single strobe cord    **#4104.32** Dual strobe cord

Other brand housings for digital still and dSLR cameras do not offer TTL compatible circuitry so only manual exposure is offered for the Ikelite Substrobes. Select the non-TTL Nikonos cord #4104.31 or #4104.32 for compatibility when connecting to the Nikonos-style female socket on the non-Ikelite housing. Follow the procedure referenced above to connect the Nikonos cord to the housing.

# EXPOSURE GUIDE

The purpose of a strobe is to illuminate the subject and bring out the subject's true colors. Due to the loss of color when light passes through water, move in on your subject to photograph thru as little water as possible.

The maximum recommended lighting distance underwater with any brand strobe is 1.8m (6'). Selecting a subject at a greater distance underwater will provide mainly bluish color silhouette type images.

## EXPOSURE LABEL

The exposure label information is primarily intended for use with traditional film cameras since digital still cameras may require less light for proper exposure. The exposure label is compatible with TTL/Auto and Manual modes and references the DS125 strobe output without the diffuser installed.

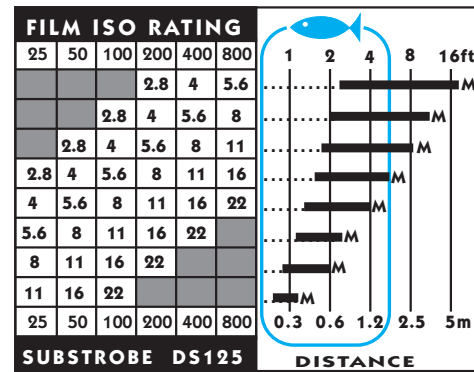

### TTL/Auto Mode example for 100 ISO film speed:

If you select f-8, you can shoot subjects up to 1.2m (4') away.

If you select f-4, you can shoot subjects up to 2.5m (8') away; however, underwater we recommend selecting subjects no farther than 1.8m (6') away.

### Full Power Manual Mode example for 100 ISO film speed:

If you select f-8, the subject should be 1.2m (4') away for proper exposure as indicated by the letter **M**.

### 1/4 Power Manual Mode example for 100 ISO film speed:

The difference between **each power setting** is one full f-stop; therefore, moving from Full to 1/4 power decreases the light output by two full f-stops. If you select f-8, then reference two less f-stops (two numbers greater) than f-8 in the chart, which is f-16. Subject should be 0.6m (2') away for proper exposure.

## CAMERA APERTURE

For balanced lighting between your subject and the background, meter the available light and set the camera aperture accordingly. Using a *narrower aperture* darkens the background. A *wider aperture* lightens the background.

# DIFFUSER #0591.3

The white diffuser can be secured to the front of the DS125 strobe when softer lighting or coverage greater than 90° is desired. The diffuser reduces the strobe output by one full f-stop while increasing the coverage angle to 100°.

## DIFFUSER INSTALLATION

1. The diffuser features three protruding ears for use in installation and removal. The protruding ears on the diffuser should be positioned away from the strobe.
2. Note the three cut-outs around the perimeter of the diffuser and the three tabs inside the perimeter of the DS125 strobe front. Place the diffuser over the front of the strobe, and rotate the diffuser so that the cut-outs align with the tabs on the front. Insert the diffuser thru the tabs, and then rotate the diffuser so the tabs on the front lock the diffuser in place.
3. To remove the diffuser, rotate the diffuser so the cut-outs align with the tabs on the front. Grasp the protruding ears on the diffuser to remove.
4. A lanyard can be attached to the diffuser by threading it thru the two circular openings on the diffuser.

## USE OF THE DIFFUSER

The diffuser reduces the light intensity by one full f-stop. When referencing the exposure guide information on the previous page, reference one less f-stop (one number greater) when the diffuser is secured to the DS125.

For the **TTL/Auto example** with ISO 100 film, if you select f-8 **without** the diffuser, you can shoot subjects up to 1.2m (4') away as stated on the previous page. If you **add the diffuser** to the strobe with the camera set at f-8, then reference one less f-stop (one number greater) than f-8 in the chart which is f-11, meaning you can shoot subjects up to 0.9m (3') away.

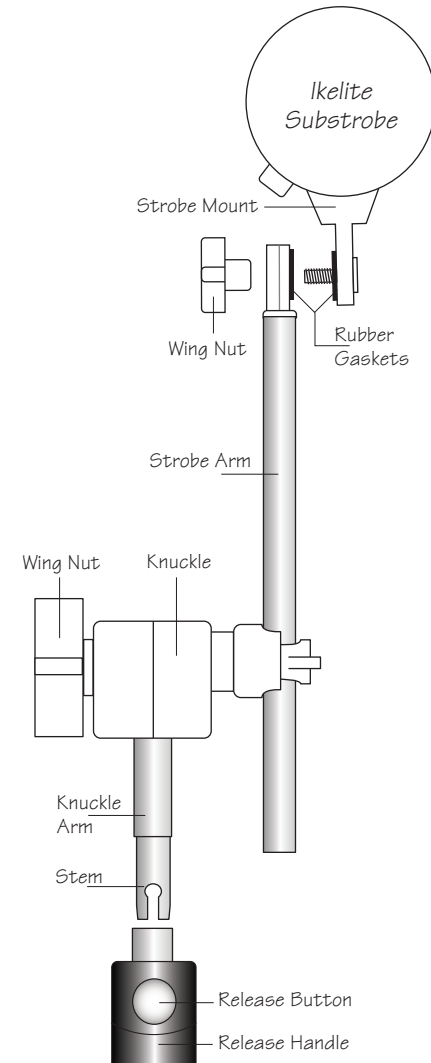
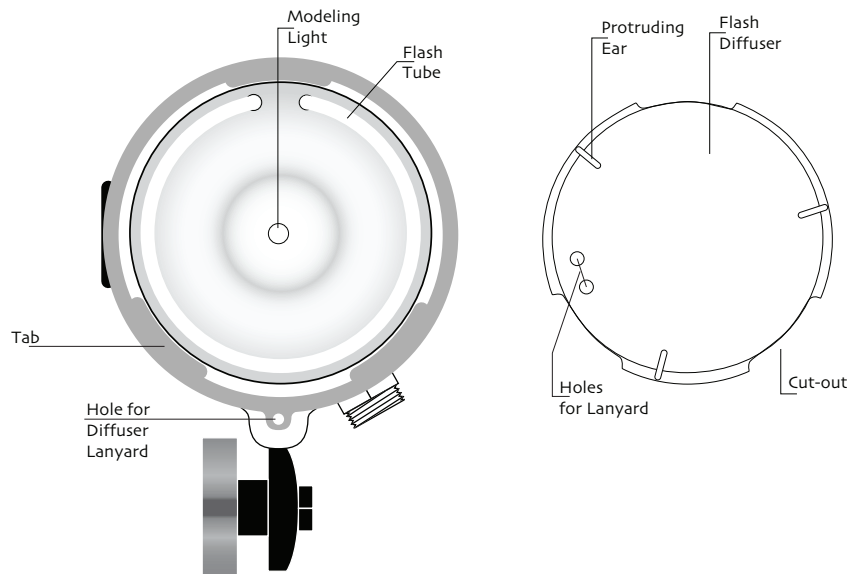

# MOUNTING THE STROBE

## IKELITE ARM SYSTEMS

Ikelite offers several arm choices compatible with the DS125. The arm is NOT supplied with the strobe unless purchased as part of a complete package.

Ikelite arm systems are designed for underwater use and may not hold the adjustment ABOVE WATER due to the weight of some large strobes. Be careful when transporting the system since some camera trays may not be able to support the weight of the strobe above water.

The strobe will feature either a paddle-type or ball-type mount on the underneath side. Please read the following arm sections for additional information.

## STROBE ARM #4075.1

The versatile Ikelite Strobe Arm offers multiple aiming positions. A second arm section with second joint can be added if desired, #4076.2

### MOUNT STROBE TO ARM

The paddle-type strobe mount may be featured on the DS125 and secures to most Ikelite arm systems. The paddle-type mount is required for compatibility with the arm 4075.1 and it allows the strobe to tilt forward and backward. The rubber gasket on the strobe mount creates friction against the arm and should NOT be lubricated.

Remove wing nut from strobe mount. Place the top of the arm against the rubber gasket on the strobe mount. Replace the wing nut and tighten to secure. This adjustment allows the strobe to pivot at the top of the arm. Rubber gasket creates friction to hold the adjustment underwater and should NOT be lubricated.

### MOUNT ARM TO HOUSING

The stem protruding at the base of the arm snaps into the release handle on the Ikelite housing. The stem also provides a convenient location for securing the optional DS Slave Sensor or EV-Controller.

Insert the stem into the release handle. Depress the handle's release button and slide the stem fully into the receptor. Release the button and it should spring back to the original position locking the arm in place.

### AIM THE STROBE

Loosen the large four-lobed knob on the knuckle and insert the arm tube. The arm can be rotated 360°, pivoted sideways, and also rotated forward and backward before retightening the knob.

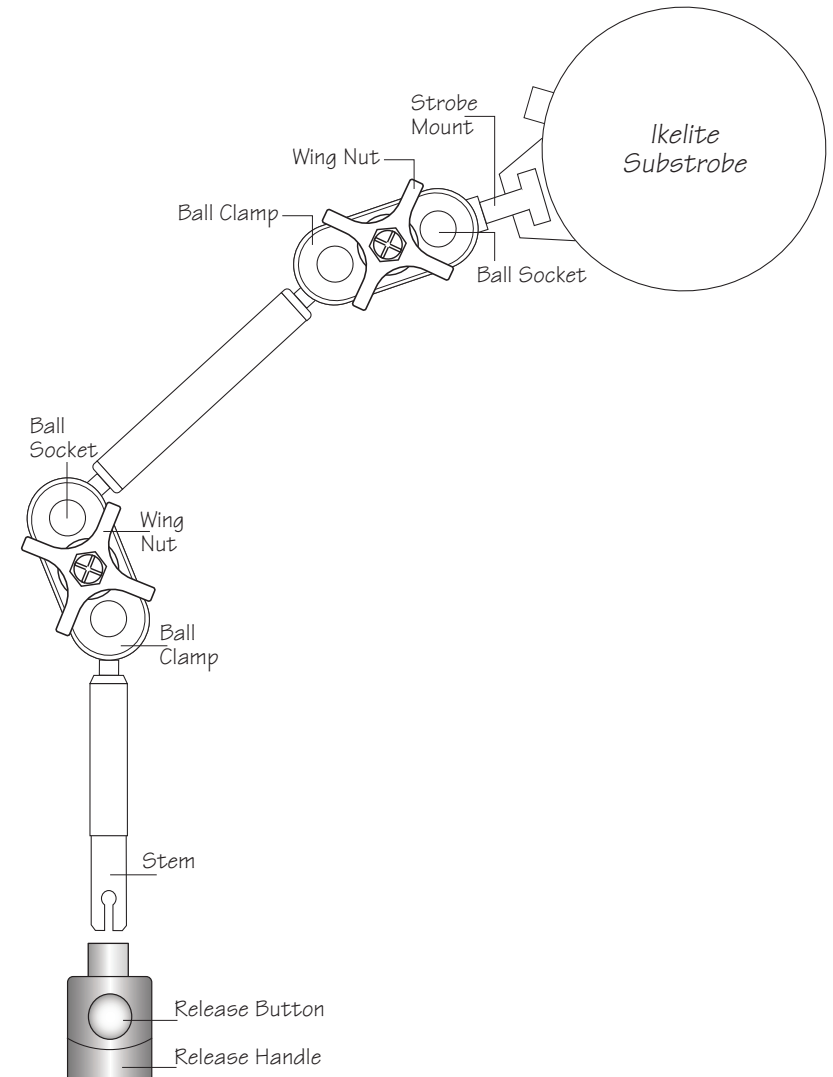

## BALL-SOCKET ARM #4086.61

The articulating Ikelite ball-socket arm secures the DS51 strobe to the contoured release handle on an Ikelite Digital Still Housing or SLR Housing. The dual ball sockets on the arm are especially versatile for macro photography since they adjust independently for a multitude of strobe mounting positions.

The ball-socket arm #4086.61 utilizes 2.5cm (1") diameter balls. Optional components are available as referenced on the following page to modify the arm.

### MOUNT STROBE TO ARM

A **ball-type** strobe mount is featured at the top of the ball-socket arm. This mount slides into the underneath side of the strobe body, and permits the use of the ball clamp at the base of the strobe.

If another mount is already secured underneath the strobe, loosen the screw and remove the original mount from the strobe. On the ball-type strobe mount, there is a screw opening at each end. Select the side that has the screw opening nearest the center, slide this end into the base of the strobe, and secure with the screw.

### MOUNT ARM TO HOUSING

The stem protruding at the base of the arm snaps into the release handle on the Ikelite housing. The stem also provides a convenient location for securing the optional DS Slave Sensor or EV-Controller.

Insert the stem into the release handle. Depress the handle's release button and slide the stem fully into the receptor. Release the button and it should spring back to the original position locking the arm in place.

### BALL CLAMPS

Loosen the wing nut on the ball clamps to adjust the positioning of the arm. Each section pivots and rotates 360° before tightening the wing nut.

The center cap limits the movement of the wing nut so that the arm cannot be accidentally disassembled. Adjust the center cap as desired.

## IKELITE BALL-SOCKET COMPONENTS

### BALL-SOCKET COMPONENTS

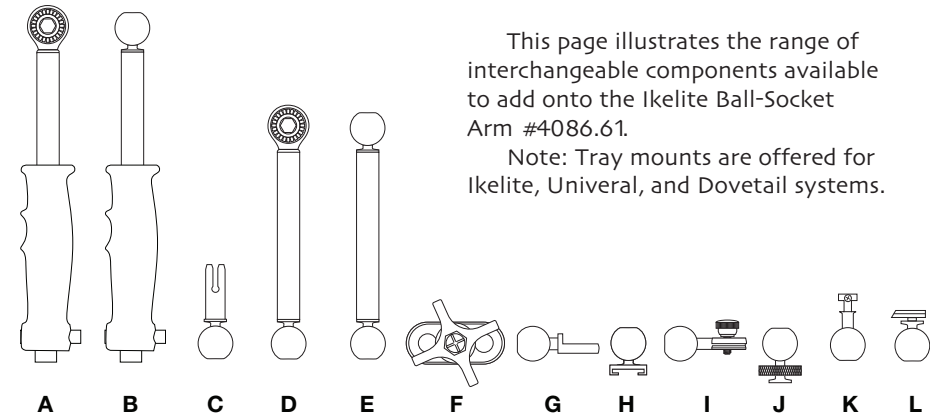

This page illustrates the range of interchangeable components available to add onto the Ikelite Ball-Socket Arm #4086.61.

Note: Tray mounts are offered for Ikelite, Univeral, and Dovetail systems.

A variety of Ikelite arm component utilizing 2.5cm (1") or 3.2cm (1.25") diameter balls are available and can be combined with the ball-socket systems of TLC, Nikon, and Ultralight that use 2.5cm (1") balls. See "Ikelite Ball-Socket Components" on page 23 for more information.

## IKELITE BALL-SOCKET COMPONENTS

- [A] QUICK RELEASE HANDLE WITH STROBE MOUNT  
#9578.07 18cm (7"), #9578.09 23cm (9"), #9578.15 38cm (15") handle
- [B] QUICK RELEASE HANDLE WITH 3.2cm (1.25") BALL  
#9581.07 18cm (7"), #9581.09 23cm (9"), #9581.15 38cm (15") handle
- [C] BALL WITH STEM  
#9571.3: 2.5cm (1") ball with extended stem (snaps into release handle).  
#9577.3: 3.2cm (1.25") ball with short stem (snaps into release handle).  
#9577.33: 3.2cm (1.25") ball with extended stem (snaps in release handle).
- [D] BALL 3.2cm (1.25") WITH STROBE MOUNT  
#9579.04 10cm (4"), #9579.06 15cm (6"), #9579.12 30cm (12") arm
- [E] BALL-TO-BALL ARM EXTENSION  
#0466.42: Both balls 2.5cm (1"), arm length 10cm (4")  
#0466.62: Both balls 2.5cm (1"), arm length 15cm (6")  
#0466.92: Both balls 2.5cm (1"), arm length 22cm (9")  
#9580.04: Both balls 3.2cm (1.25"), arm length 10cm (4")  
#9580.06: Both balls 3.2cm (1.25"), arm length 15cm (6")  
#9580.12: Both balls 3.2cm (1.25"), arm length 30cm (12")  
Ball-to-ball adapter #0466.51: Combine different diameter ball arms.  
One 2.5cm (1") ball connected to one 3.2cm (1.25") ball, length 13cm (5").
- [F] BALL CLAMP  
#9571.2: For arm components featuring 2.5cm (1") balls.  
#9571.23: For arm components featuring 2.5cm (1") balls,  
also features mounting stud extension usable for mounting the  
optional Ikelite DS Sensor or EV-Controller.  
#9577.2: For arm components featuring 3.2cm (1.25") balls.
- [G] IKELITE TRAY MOUNT  
#9577.71: 2.5cm (1") ball with tray mount for Ikelite tray/handle.  
#9577.1: 3.2cm (1.25") ball with tray mount for Ikelite tray/handle.
- [H] UNIVERSAL MOUNT #9577.5: 3.2cm (1.25") ball with shoe mount.
- [I] DOVETAIL TRAY MOUNT #9577.7: 3.2cm (1.25") with dovetail mount.
- [J] NIKONOS MOUNT #9577.6: 3.2cm (1.25") with Nikonos IV/V shoe.
- [K] SUBSTROBE 50, 125 MOUNT: Use ball clamp to secure strobe mount  
to ball-socket arm.  
#9571.4: 2.5cm (1") ball with mount for DS50, SS50, DS125 strobe.  
#9577.41: 3.2cm (1.25") ball with mount for DS50, SS50, DS125 strobe.
- [L] SUBSTROBE 100A, 200 MOUNT: Use ball clamp to secure strobe mount  
to ball-socket arm.  
#9577.43: 2.5cm (1") ball with mount for SS100A, SS200 strobe.  
#9577.42: 3.2cm (1.25") ball with mount for SS100A, SS200 strobe..

## RECOMMENDATIONS

### VISUAL INSPECTIONS

Visual inspections are important. Take the time to visually inspect the system above water. An improper seal or loose connection can cause a lot of damage. Always check for leaks once you place the system in the water.

### INSURANCE

We recommend adding an ALL RISK floater to your homeowner's insurance policy in the event you damage, flood, or lose your camera or strobe. While the Ikelite Substrobe has a limited warranty against manufacturing defects, it does not cover customer neglect.

### TECHNIQUES

Add a strobe to illuminate the subject and bring out the subject's true colors. Due to the loss of color when light passes through water, move in on your subject to photograph thru as little water as possible. The maximum recommended lighting distance underwater with **any brand strobe** is 1.8m (6'). Selecting a subject at a greater distance underwater will provide mainly bluish color silhouette type images.

The white diffuser can be secured to the front of the DS125 strobe when softer lighting or coverage greater than 90° is desired. The diffuser reduces the strobe output by one full f-stop while increasing the coverage angle to 100°.

For balanced lighting between your subject and the background, meter the available light and set the camera aperture accordingly. A **narrower aperture** darkens the background. A **wider aperture** lightens the background. If the exposures are consistently over or under exposed, an exposure compensation control may be featured on the TTL/Auto exposure camera that can be adjusted to compensate accordingly.

For more natural looking photos, add a second external strobe to control the highlights and shadows of your subject. For TTL automatic exposure, both Ikelite strobes should be connected via dual sync cord whenever possible. If maximum control for manual exposure is preferred, choose the optional Ikelite EV-Controller #4100.6, which provides 10-manual power settings in half-stop increments. The EV-Controller can be triggered using the built-in slave sensor or an optional sync cord can be connected.

Always carry spare batteries. Weak batteries cause many camera and strobe problems. Prolong the battery life by recharging the NiMH monthly even when not used. Do not discharge the NiMH completely as this can cause permanent damage.

### RAPID USE

The DS125 strobe should NOT be continuously fired more than 15 times in rapid succession. In such instances, allow the DS125 strobe to cool off for at least 10 minutes.

## MAINTENANCE

The Ikelite SUBSTROBE should be given the same care and attention as your other photographic equipment. In addition to normal procedures, we strongly recommend that this strobe be returned to Ikelite periodically to be checked and pressure tested.

1. We suggest storage of your Substrobe with the locking lever OPEN to allow any hydrogen/air mixture to escape.

2. Always rinse the exterior of the Substrobe with fresh water after use. The strobe can be cleaned by soaking it in a mild soapy solution. Use liquid soap; RINSE and DRY the strobe before storage.

3. The o-ring #0132.36 is located on the inside rim of the DS125 battery pack. Keep the o-ring and the sealing surfaces clean. **DO NOT** stretch the o-ring when cleaning. It is not necessary to lubricate the o-ring. Never use spray lubricant because it may crack the plastic.

4. Keep the strobe bulkhead connector threads clean and lightly lubricated. Also keep the sync cord o-ring and threads clean and lightly lubricated.

5. Recharge the NiMH pack after each use; **DO NOT** fully discharge the NiMHs because you will shorten the battery life. Store the NiMH pack fully charged, and recharge the pack for a few hours each month. **DO NOT** disassemble the battery pack.

6. The strobe is factory sealed; **DO NOT** disassemble.

### CAUTION LUBRICANT

- Use only Ikelite brand silicone lubricant with Ikelite brand o-rings as other brand lubricants can cause the Ikelite o-rings to swell in size.
- **DO NOT** use spray lubricant as it may cause cracking of the plastic.
- Ikelite silicone lubricant is provided for the sync cord o-ring. Use only enough lubricant to lightly cover the o-ring; wipe off any excess with a clean cloth.
- Lubricant only reduces friction; it is **NOT** a sealant.

## FLOODING

The DS125 electronics are safely sealed separately from the battery pack. Should the battery pack flood, flush with fresh water and dry thoroughly. Determine the cause of flooding. REPLACE THE COMPLETE BATTERY PACK #4066.5. Never re-use batteries that have been wet. The water could create an internal short circuit at some later date causing a potential explosion. **DO NOT** disassemble the strobe, NiMH pack.

Send the strobe head in for service if there is any discoloration of the battery pins.

## TROUBLESHOOTING

### STROBE WILL NOT FIRE

1. Check the strobe ready light. Turn the strobe OFF and then back ON. Make sure that the switch has actually clicked into position.
2. Make sure the charger is operating properly and the NiMHs are fully charged.
3. Check the mode switches on the camera and strobe.
4. Check the sync cord connection at the camera and strobe.
5. When using a sync cord between the camera and strobe, disconnect the cord from the camera, but leave the cord connected to the strobe. Short across the pins on the end of the cord to test fire the strobe. If you short across the wrong receptacles on a TTL sync cord, it may damage the Substrobe electronics.

**Ikelite TTL Cord:** Position the raised half-circle encompassing the receptacles towards you. Short across the center and lower right receptacles.

**Nikonos TTL Cord:** Position the indexing groove towards you. Short across the back and right receptacles.

If the strobe fires, the problem lies somewhere in the camera. Otherwise, return the strobe to authorized Ikelite personnel. **DO NOT** self-repair.

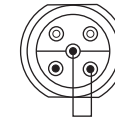

Ikelite



Nikonos

### FLASH CORD CONTACTS

# **SERVICE**

## **IKELITE LIMITED WARRANTY**

Ikelite Substrobes are warranted against any manufacturing defects for a period of two (2) years from the date of purchase. All other Ikelite products are warranted against any manufacturing defects for a period of one (1) year from the date of purchase. Defective products should be returned prepaid to Ikelite. Ikelite will, at its discretion, repair or replace such products, and will return to customer prepaid. All other claims, of any nature, including but not limited to bulb failure are not covered. Except as mentioned above, no other warranty expressed or implied, applies to this Ikelite product.

*We recommend adding an ALL RISK floater to your homeowner's insurance policy in the event you damage, flood, or lose your camera or strobe.  
Ikelite warranty does NOT cover customer neglect.*

## **RETURNING PRODUCTS FOR SERVICE**

Ikelite is most interested in performing any service to assure that all products perform as intended. For repair service, return the Ikelite product to the address below with your name, address, phone number, and a brief description of the problem. Evidence of purchase date must be provided to obtain warranty service. Thank you.

### **IKELITE UNDERWATER SYSTEMS**

50 West 33 Street  
P.O. Box 88100  
Indianapolis, IN 46208 USA  
317.923.4523

**www.ikelite.com**  
Email: [ikelite@ikelite.com](mailto:ikelite@ikelite.com)

## **IKELITE UNDERWATER SYSTEMS**

50 West 33rd Street  
P.O. Box 88100  
Indianapolis, IN 46208 USA  
317.923.4523

**www.ikelite.com**  
Email: [ikelite@ikelite.com](mailto:ikelite@ikelite.com)