

Ikelite Digital Housing

instruction manual

#6148 for Canon SX1 IS

#6148.01 for Canon SX10 IS, SX20 IS

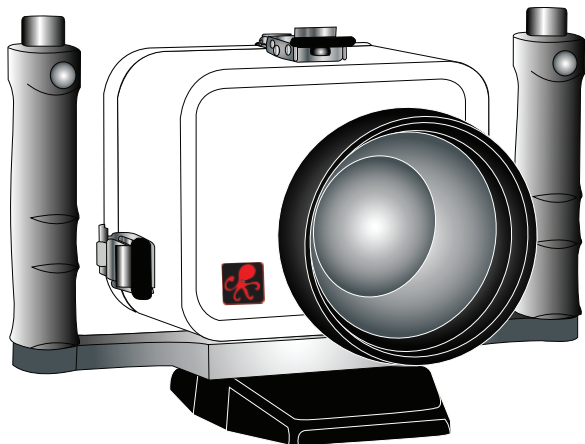

Congratulations on your purchase of an Ikelite Digital Camera Housing. Ikelite has over 45 years of experience in the underwater photographic and lighting market. Our products are designed and built in the USA by Ikelite for both the professional and amateur photographer.

The clear housing permits instant visual inspection of the camera and all sealing surfaces as well as complete monitoring of controls and camera LCD screens.

Ikelite Digital Housings are slightly negative in salt water for stability. This housing has been water pressure tested at the factory to 200' (60m).

Please Read

We suggest that you read this instruction booklet thoroughly before use. If you are new to underwater photography, be sure to read the General and Photo Tips sections.

We also suggest that you read your camera manual thoroughly to have a full understanding of each camera function.

Initial Camera Setup

1. Set ISO to 80.
2. Set camera mode dial to "A" Aperture priority.
3. Set Flash Mode to "Auto" (lightning bolt in LCD).
4. When using external strobes, set built-in flash to "Off".
5. For General photography, set aperture to f4.0.
6. For Macro photography, set aperture to f8.0.
7. Set White Balance to "Auto".
8. Set Image Size to "L".
9. Set Metering to "Center-Weighted Avg.".

2

SX1, SX10, SX20 - Front View

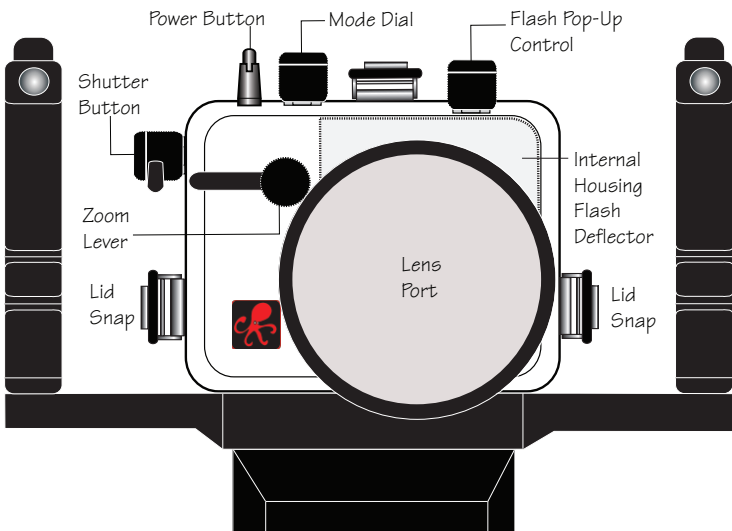

SX1 - Back View

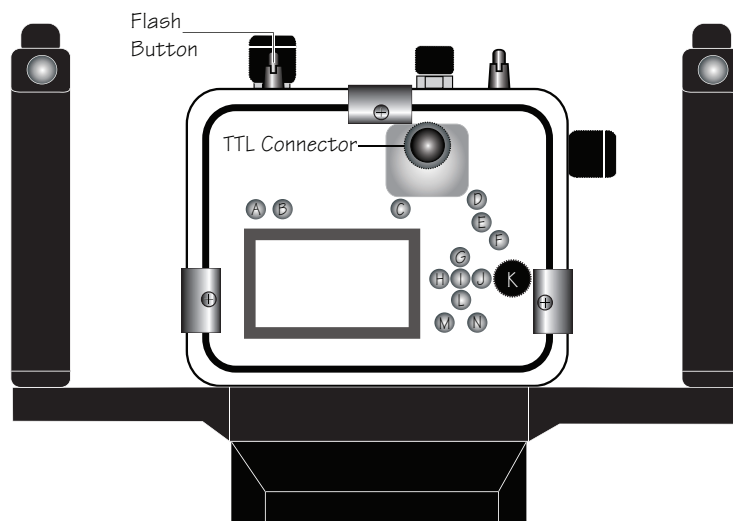

- | | | | |
|------------------|---------------------------|------------------|-------------|
| [A] Print/Share | [E] +/- Exposure/Jump | [I] FUNC./SET | [M] Display |
| [B] Aspect Ratio | [F] AF Frame/Single Erase | [J] ISO | [N] Menu |
| [C] Movie | [G] Manual Focus | [K] Control Dial | |
| [D] Playback | [H] Macro | [L] Cont. Shoot | |

SX10, SX20 - Back View

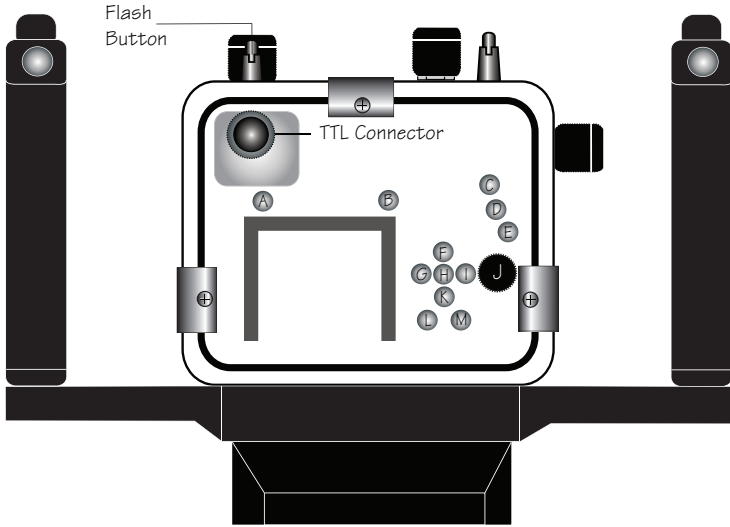

- | | | | |
|------------------|--------------------------|------------------|----------|
| [A] Shortcut | [E] Frame Selector/Erase | [I] ISO | [M] Menu |
| [B] Movie | [F] Manual Focus | [J] Control Dial | |
| [C] Playback | [G] Macro | [K] Self-Timer | |
| [D] +/- Exposure | [H] FUNC./SET | [L] Display | |

5

Opening the Housing

1. Lid Snaps have a **Lock**.

To open, push Lid Snap Lock forward and lift as shown. Keep pressure on the Lid Snap so it does not fly open quickly. *Some lid snaps have a lot of spring tension once they go over center, so keep a firm grip on the lid snap. Lid Snaps may be opened one at a time.*

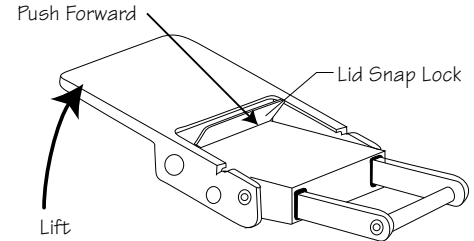

Installing the Camera

1. Pull out on each housing control until it stops. This will get the controls out of the way for installation of the camera.
2. Remove the back from the housing.
3. The mounting tray for the camera is secured to the housing back. Position the camera on the tray.
4. Slide the housing Hotshoe Connector into the Camera Hotshoe Mount (**PAGE #7 - Diagram A**). Slide the connector forward until it stops. This must be done before the camera is secured with the mounting bolt (**Page #8 - Diagram B**).

NOTE: If you are using an EV Controller and NOT hard-wiring your strobes directly to the housing, leave the housing hotshoe disconnected from the camera and raise the camera flash. You will also need to install the Flash Deflector (**Page #11**).

6

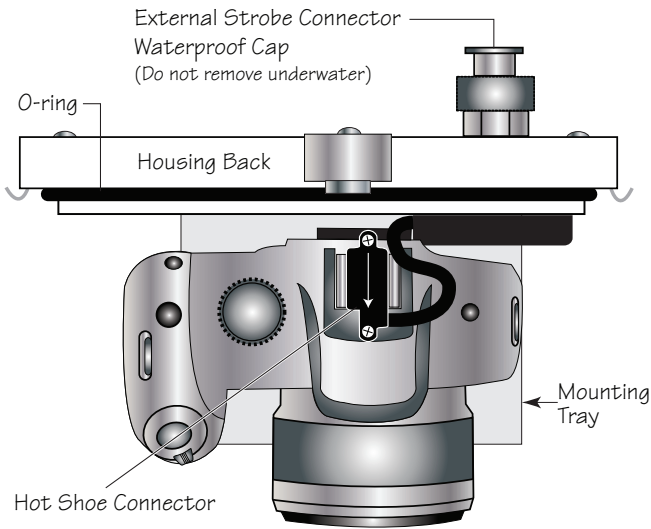

Hotshoe Connector - (SX10IS Shown)

Diagram A

CAUTION:

Do not remove the External Strobe Connector Waterproof Cap unless an external sync cord is going to be plugged in. Do not remove the Waterproof Cap or Sync Cord underwater.

7

Installing the Camera (cont.)

5. Using a coin or screwdriver (preferred), secure the camera with the mounting bolt which threads into the camera's tripod socket (**Diagram B**).

CAUTION:

Some camera tripod socket threads are plastic. The mounting tray bolt is metal. Do not cross thread or over tighten as you may damage the camera tripod socket threads.

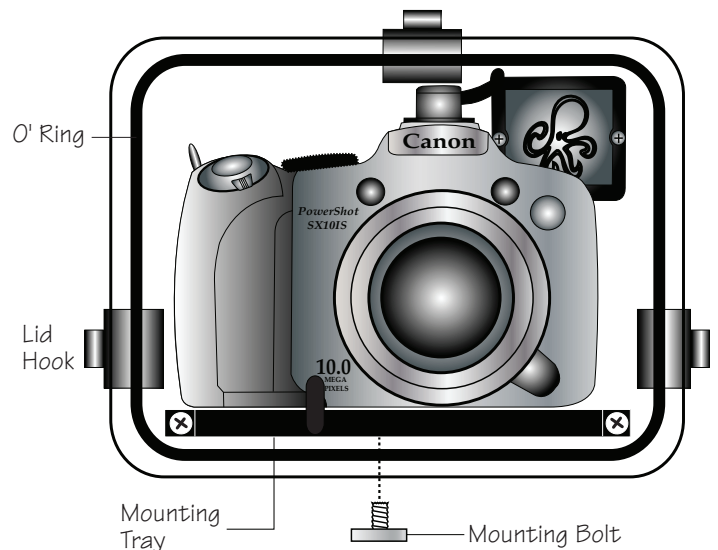

CAMERA / MOUNT - (SX10IS Shown)

Diagram B

8

Closing the Housing

1. Place housing face down in your lap or on flat surface.
2. Check to see that there is an o-ring on the housing back and that it is clean and in its proper location.
3. Guide the back into the housing front. The o-ring should touch the housing all the way around. There should be an even gap all the way around between the housing and the housing back.
4. Lift the lid snaps so they are extended and place each lid snap into the corresponding hook on the housing back.
5. To close the housing, push down on the lid snaps until they snap into place. Lid snaps on opposite sides of the housing should be closed at the same time. Be sure they are down far enough to engage the lock.

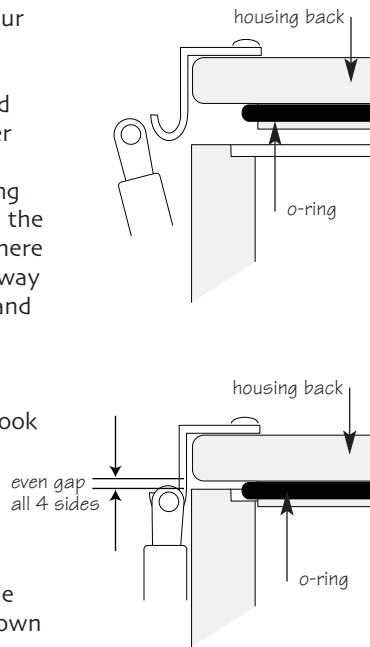

Double check - Once the housing is closed, check the o-ring seal. Check the gap between the housing back and the housing. It should be even all the way around the housing. Look through the clear plastic back at the o-ring. You should see a darkened area where the o-ring is compressed against the housing back. If you do not see an even black compression seal all the way around the back, open the lid snaps, reseal the housing back and close the lid snaps. Visually check the seal again.

9

Using Flash

Due to the large housing port diameter, the internal camera flash **cannot** be used to illuminate subjects underwater. An internal housing flash deflector (supplied) can be installed to the front inside port area of the housing above the port opening. The deflector will deflect the camera flash when using an EV Manual Controller. The deflector will redirect the camera's flash to the EV Controller which controls the external strobe output. To attach inside the housing, remove velcro backing, align and attach the deflector inside the housing as shown below.

NOTE: The deflector is **not** needed when an Ikelite DS digital strobe is connected (hard-wired) directly to the housing (recommended).

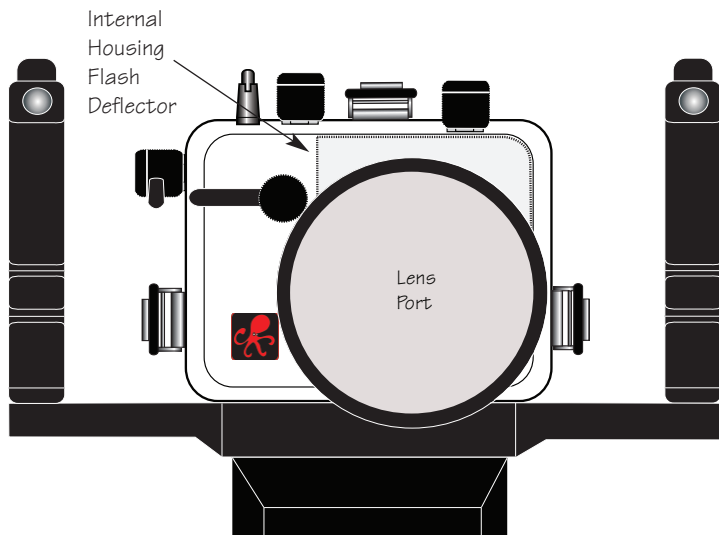

11

Checking Controls

Once the housing has been closed, make sure the housing controls line up with the corresponding camera controls. If the housing controls are misaligned slightly, make sure the camera hold down bolt has been tightened down firmly so the camera is flat against the tray.

Turn Camera On

Turn the camera on and operate each of the housing controls to get a feel for using the camera in the housing. Take a few pictures above water with the camera in the housing.

Zoom Control

(NOTE:) After you have used the housing's zoom control, it must be returned to the center position to disengage. If the housing zoom control is pushing the zoom lever in either direction, you may not be able to take a picture or access any other function because the camera is receiving a signal from the engaged zoom control.

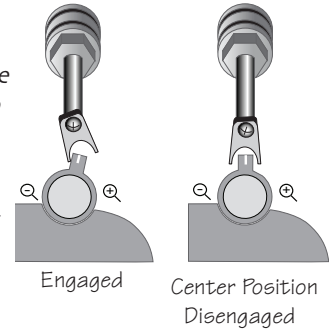

Housing Lens Port and Accessory Lenses

Treat the Plexiglas in the lens port as a camera lens. After use, rinse and gently dry the lens port to avoid water spotting. To clean, use a mild soap solution or lens cleaner.

Do not use alcohol or window cleaner on the Lens Port.

No accessory or wide-angle lenses can be used with this housing.

10

Using External Strobes

For the best photographic results underwater, we recommend using Ikelite External Strobes. This housing has Conversion Circuitry built into the housing back, eliminating the need for an EV Controller. The Conversion Circuitry provides real Canon TTL flash when used with an Ikelite DS Digital substrobe(s) and the #4103.51 single or #4103.52 dual sync cord, connected directly to the housing.

See **page 16** for DS Substrobe compatibility with the Conversion Circuitry.

Using Non-Ikelite or Ikelite Non-DS Substrobes (Substrobe 50, 100A, 200, 400) with this Housing.

The Conversion Circuitry is automatically disabled when used with a Non-Ikelite or Non-DS Substrobe. These Substrobes can be used in their manual mode utilizing any power settings provided on the Substrobe.

12

Using Ikelite DS Digital Strobes

For the best underwater photographic results, we recommend adding an external DS-digital strobe connected to the housing with a #4103.51 TTL Sync Cord and a SA-100 Ball/socket arm (Page #14).

Ikelite DS series Substrobes are industry favorites for their warm, even coverage and lightning fast recycle time. Being farther from the camera lens, the optional DS Substroke aids in reducing the illumination of particles in the water and helps to eliminate backscatter. When used in conjunction with the EV-Controller, the DS51 Mode switch is set to the TTL setting and the EV-Controller provides ten power settings in half-stop increments.

Ikelite Substroke DS51

The compact, lightweight and affordable Substroke DS51 is well suited for general and macro photography. This strobe can easily switch between TTL/Auto and any of the six (6) manual power settings for complete control over lighting the subject. The strobe's wide-angle diffuser increases the angle-of-coverage up to 80 degrees.

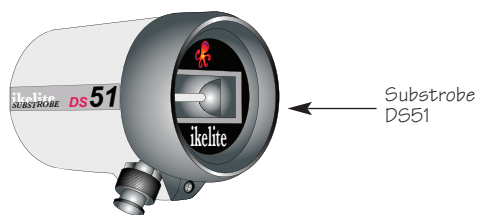

13

Using Strobes (cont.)

Ikelite Strobe Packages

Substroke DS-51 Package #3944.51 includes #4086.61 Arm System with Ikelite TTL sync cord.

Substroke DS-161 Package #3945.01 (Recommended) includes #4086.61 Arm System and 1.5 hour Smart Charger with Ikelite TTL sync cord.

Substroke DS-200 Package #3944.60 includes #4085.26 Arm System and 1.5 hour Smart Charger with Ikelite TTL sync cord.

Please Read If Using an EV-Controller

The EV-Controller used with Ikelite DS Substrobes has two user settings. One setting is for strobe selection, the other is for pre-flash or non pre-flash. **This camera uses pre-flash**, thus the EV-Controller should be set to the pre-flash position when used with this camera as a slave. If hard-wired to the housing, set the EV-Controller to Non pre-flash. **TTL flash control is not available when using an EV-Controller, and therefore an EV Controller is not recommended for use with this housing.**

NOTE: Do not attach the housing hotshoe to the camera when using the EV Manual Controller. If attached, the hotshoe will not allow the camera flash to fully extend.

Complete information regarding our full line of Ikelite products including strobes and optional accessories available at www.ikelite.com

15

Using Strobes (cont.)

DS161 Movie Substroke

The DS161 Movie Substroke combines all of the functionality of our renowned DS160 with a powerful 500 lumen LED video light. Three super-bright LEDs are arranged behind a special optical element to provide 45 degrees angle of coverage free of hotspots. The DS161 flash covers the equivalent of an 18mm lens or 100 degrees w/diffuser installed. It is the ideal choice when using wide angle lenses greater than 80 degrees. It also features a 1.5 second recycle time and 225 flashes per full charge.

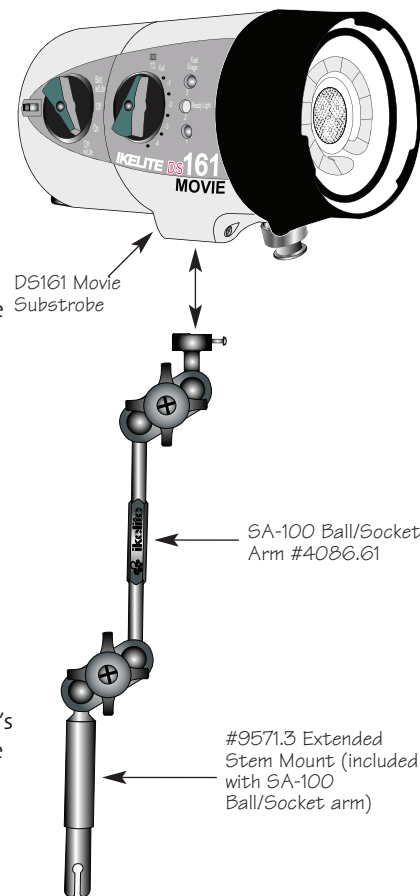

14

Strobe Arms

The top of the housing's rubber handles utilize Ikelite's Quick-Release Arm, available as the recommended SA-100 Arm system (pictured).

NOTE: DS Substroke Update information

DS50 Substrobes

- DS50 SubStrobes with a Serial Number below 63,850 can not be updated to operate with the Conversion Circuitry.
- DS50 SubStrobes with a Serial Number between 63,850 and 69,999 operate with the Conversion Circuitry, but require an update to provide optimum performance.
- DS50 Substrobes with a Serial Number of 70,000 or higher, or with one of the two following labels in the battery compartment provide optimum performance with the Conversion Circuitry and do not need an update.



DS125 Substrobes

- DS125 Substrobes with a Serial Number below 2,500 must be updated to operate correctly with the Conversion Circuitry.
- DS125 Substrobes with a Serial Number between 2,501 and 4,900 will operate with the Conversion Circuitry, but require an update to provide optimum performance.
- DS125 Substrobes with a Serial Number of 5,000 or higher, or with one of the two following labels in the battery compartment, provide optimum performance with the Conversion Circuitry and do not need an update.



To Update Your Substroke:

Send to the Ikelite address on the back page of this manual or contact Ikelite for more information.

16

Base Quick Release:

The Housing Base may be removed from the Housing Tray/Handles by following the diagram below. Reverse this procedure to install.

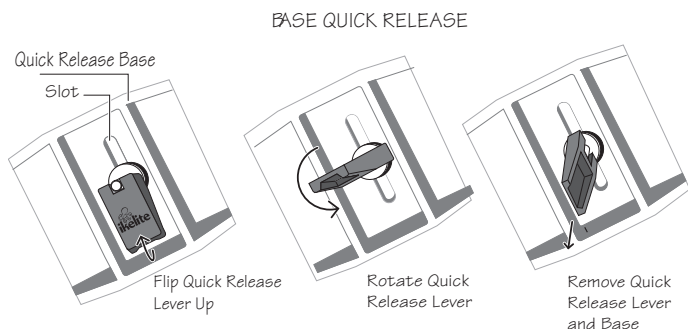

Maintenance

The Ikelite Digital Housing should be given the same care and attention as your other photographic equipment. In addition to normal maintenance, we recommend that the housing be returned to Ikelite periodically to be checked and pressure tested.

1. **Do Not** leave the camera and housing in direct sunlight for prolonged periods. Heat may damage the camera.
2. **Do Not** ship the camera in the housing.
3. Before using the housing, always check the tightness of the **set screw** in each control knob. Check each **control gland** penetrating the housing to make sure they are tight. There is a slight chance that either could vibrate loose during travel.

17

Lubricants

1. Ikelite provides silicone lubricant with the housing. We recommend you use only Ikelite lubricant on Ikelite products as some other brands may cause the o-ring to swell and not seal properly.
2. Use only enough lubricant to lightly cover control shafts and o-rings. Wipe off any excess lubricant with a clean cloth. Lubricant is not a sealant, it is used to reduce friction. Excessive lubricant can collect sand and dirt which may interfere with proper sealing.

CAUTION

Never use spray lubricants as the propellant ingredient can cause the plastic housing to crack.

Control Maintenance

Ikelite controls are designed to provide years of reliable service with minimal maintenance.

1. Push button controls require no maintenance other than rinsing in fresh water after saltwater use. If a push button control becomes difficult to push or if it sticks when depressed, soak the housing in luke warm fresh water. After a few minutes, operate the push button. If this does not correct the problem, return the housing to Ikelite for maintenance.
2. Some of the controls have long shafts. These controls can be pulled out, exposing the shaft (see **Diagrams C & D** on pages #20 & #21). To lubricate the control, gently pull on the knob until the stainless steel shaft is exposed. Lightly lubricate the shaft, then move the shaft in and out several times. This will lubricate the x-ring in the Ikelite control gland. This should be done before using the housing after a prolonged storage period, or once a week when the housing is in constant use.

19

Maintenance (cont.)

4. Keep the back o-ring clean and lightly lubricated. To lubricate, remove the o-ring from the back. Put a small amount of Ikelite lubricant on your fingers. Pull the o-ring through your fingers to apply a light coating of lubricant. Only apply enough lubricant to make the o-ring feel slick. **Do Not stretch the o-ring.** This light coating of lubricant will help to keep the o-ring from drying out and will help to show a dark sealing line when the housing back is properly sealed.
5. Keep the area where the o-ring fits and the sealing surface of the housing clean.
6. Rinse the housing exterior thoroughly in fresh water after each salt water use. Dry with a soft cloth. Dry lens port to eliminate water spotting. After several uses in salt water, soak the housing exterior in a mild soap solution, rinse and dry, before storing. When storing the housing, remove the back o-ring, lightly lubricate, and place in a plastic bag. Place the plastic bag with o-ring inside the housing for safe keeping.
7. If removing a housing push button, **Do Not** re-use the E-clip. Contact Ikelite for replacement E-clips (part #0319.12).

18

Control Maintenance Cont.

3. Some of the controls have a short shaft and cannot be pulled out exposing the shaft for lubrication. In the unlikely event one of these controls sticks or becomes difficult to operate you can remove the control from the housing and lubricate it, or return the housing to Ikelite for maintenance. To remove the control (**Diagram C**), loosen the set screw in the knob (allen wrench required); remove the knob. If there is salt or dirt build-up on the exposed control shaft, clean the shaft. Open the housing and gently slide the control shaft out of the control gland. Clean and lightly lubricate the shaft, including the end of the shaft. Slide the shaft back into the control gland and gently slide it back and forth a few times without fully removing the shaft from the gland. Replace the knob noting the flat area on the shaft. The set screw in the knob should tighten down against the flat area on the control, so the knob does not turn on the shaft.

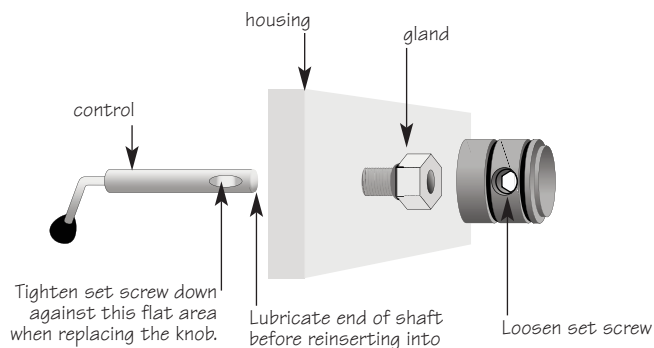
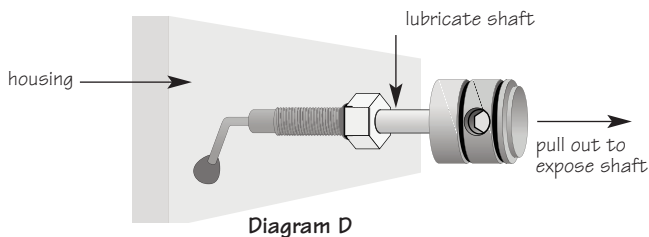

Diagram C

20



General Tips

1. Due to the power required to operate the camera, flash, and LCD screen, it is a good idea to start each dive with a fresh set of batteries.
2. Some cameras reset their flash to AUTO when the camera is turned on. If you prefer another setting be sure to select it.
3. As soon as you enter the water, take a moment and check the housing to see that it is properly sealed.
4. Next, check to see if there are any bubbles on the face of the lens port. If there are, take your finger and remove them. If there are bubbles on the lens port they can produce soft focus spots in your photographs.
5. If you are shooting with the camera's built-in flash and the camera lens is set to the widest angle, you may need to zoom the lens slightly or a shadow may appear in the lower left corner of close-up photographs. The lens port may block some of the light. Installing the flash diffuser will help to eliminate the shadow. *(You can test this above water)*

NOTE: To shoot photographs closer than 2 feet (0.6m), you should use an external strobe such as the DS51 or DS161. You can position the external strobe so nothing blocks the light path between the strobe and the subject.

21

Photo Tips Cont.

6. When using daylight or flash, if your camera consistently over or underexposes the image, you may want to adjust your camera's exposure compensation settings. Many cameras allow you to adjust both available light and flash exposure with an EV control in the camera's menu.
7. Many photographers transfer their images to the computer where they can fine tune the appearance of the image. Many of the image manipulation programs make you think you can magically correct any image taken and make a good picture. One thing to remember when using an image manipulation program, is that if the image is overexposed, much of the color is missing. If the color is missing you cannot adjust it. If images are slightly underexposed, the color is there, but it is just dark and you can adjust it to some degree. So if you error in exposure, it is better to have the image slightly underexposed rather than over exposed.

23

Photo Tips

1. The number one rule in underwater photography is eliminate as much water between camera and subject as possible. Get as close as you can to the subject, then use the zoom. If you are using flash, subjects beyond 6 feet (1.8m) will not have much color.
2. The camera's built-in flash is very close to the camera lens. The flash can light up any suspended particles in the water and they can be recorded in your picture. This effect is called backscatter. To eliminate as much backscatter as possible, photograph close. Photograph in clear water; do not stir up the sand or silty bottom. If backscatter becomes a problem in the environment you are photographing, an external flash will help eliminate much of the backscatter.
3. Many digital cameras have a slight lag time between when you press the shutter release button and the camera actually takes the picture. Hold the camera steady a second or two after pressing the shutter release button.
4. Do not shoot down on subjects as they will quite often blend into the background and be difficult to see in the photograph. Shoot subjects straight on or shoot up at a slight angle using the blue water as a contrasting background.
5. Underwater flash is used to restore the warmer colors filtered out by the water as well as to illuminate the subject. When photographing underwater, set the camera to use flash on every shot. If the camera's flash is set to AUTO and the sun is behind your subject, the camera may see enough light and not fire the flash. With the sun behind the subject, the subject is shaded (dark) and needs flash for a good exposure.

22

Ikelite Limited Warranty

All Ikelite products are warranted against any manufacturing defects for a period of one year from the original date of purchase. Defective products should be returned prepaid to Ikelite. Ikelite will, at its discretion, repair or replace such products, and will return to customer prepaid. All other claims, of any other nature, are not covered. Except as mentioned above, no other warranty expressed or implied applies to this Ikelite product.

Returning Products for Service

Ikelite is most interested in performing any service to assure that all products perform as intended. For repair or service, return the product to the address below with your name, address, phone number, and a brief description of the problem. Evidence of purchase date must be provided to obtain warranty service. Normal service turnaround time is approximately 2-3 weeks.



Ikelite Underwater Systems
50 W 33rd Street
Indianapolis, IN 46208 USA

When returning products send "attn. Repair Dept."

317-923-4523

"general questions" e-mail: ikelite@ikelite.com
www.ikelite.com

Digital 6148_6148.01-04-1209